



Municipality of Princeton, NJ

Mayor and Council of Princeton

Meeting Agenda

400 Witherspoon St
Princeton, NJ 08540

Monday, April 13, 2026

7:00 PM

Main Council Chambers

I. JOIN MEETING - PLEASE CLICK LINK BELOW:

<https://us02web.zoom.us/j/81547421712>

Webinar ID 815 4742 1712

II. STATEMENT CONCERNING NOTICE OF MEETING

Notice of this meeting was provided in accordance with the requirements of the Open Public Meetings Act and State regulations governing public meetings, including the time, date and location of the meeting and clear and concise instructions to the public for accessing the meeting and making comments. In addition, the agenda and all related materials were posted electronically and made available to the public on Princeton's meeting portal in advance of the meeting.

III. LAND ACKNOWLEDGEMENT

"We gather today on the land of the Lenni Lenape. As members of the Princeton community, we aspire to show appreciation, respect, and concern for all peoples and our environment. We honor the Lenape and other Indigenous caretakers of these lands and waters, the elders who lived here before, the Indigenous today, and the generations to come"

IV. ROLL CALL

V. PLEDGE OF ALLEGIANCE

VI. APPROVAL OF MINUTES

1. [0030](#) Mayor and Council of Princeton-Closed Session-November 5, 2025

VII. ANNOUNCEMENTS/REPORTS

1. [0031](#) Annual Report on the Center for Modern Aging Princeton- Drew Dyson, PhD, CEO

VIII. RESOLUTIONS

1. [R-26-119](#) Resolution of the Mayor and Council of Princeton Authorizing the Purchase of Firefighter Protective Gear and Equipment from MES for \$63,285.98 utilizing New Jersey State Contracts 25-COMG-131371 and 25-COMG-131390

2. [R-26-120](#) Resolution of the Mayor and Council of Princeton Authorizing an Increase of \$6,500.00 to the Not to Exceed Amount for the Professional Services Agreement with PS&S, LLC for Professional Engineering Services in Connection with the Terhune Road Pedestrian Improvements Project for a New Not to Exceed Amount of \$185,000.00
3. [R-26-121](#) Resolution of the Mayor and Council of Princeton Authorizing the Award of a Professional Services Agreement to One Water Consulting LLC for a Watershed Assessment Report for an Amount Not to Exceed \$29,700.00
4. [R-26-122](#) Resolution of the Mayor and Council of Princeton Authorizing Site License Agreements with Crown Castle Fiber LLC for 288 Witherspoon Street, 1288 Stuart Road, and 1267 Great Road
5. [R-26-123](#) Resolution of the Mayor and Council of Princeton Authorizing Change Order #1 with Colonnelli Brothers, Inc. in the Amount of \$314,670.00 for the Rehabilitation/Replacement of Two Pedestrian Footbridges in the Mountain Lakes Preserve, for a new Total Amount of the Construction Agreement of \$1,261,870.00
6. [R-26-124](#) Resolution Authorizing the Submittal of a Preserve New Jersey Capital Level II Grant Application for the Project “Rehabilitation of a Historic Stone Arch Bridge at the Mountain Lakes Preserve, Committing to the Dedication of \$157,335 in Matching Funds, and Authorizing Municipal Representatives to Sign the Assurances Documentation
7. [R-26-125](#) Resolution of the Mayor and Council of the Municipality of Princeton Authorizing the Award of a Contract to HG Media for 2026 Princeton Podcast Sponsorship for an Amount Not to Exceed \$7,800.00

IX. CONSENT AGENDA

1. [R-26-126](#) Resolution of the Mayor and Council of Princeton Authorizing the Payment of Bills and Claims
2. [R-26-127](#) Resolution of the Mayor and Council of Princeton Authorizing a Shared Services Agreement for Specialized Health Services with the Township of Hamilton in the Not to Exceed Amount of \$4,000.00
3. [R-26-128](#) Resolution of the Mayor and Council of Princeton Authorizing Appointments to Boards, Commissions, and Committees
4. [R-26-129](#) Resolution of the Mayor and Council of Princeton Approving the Placement of Pole Banners along Nassau Street by the Princeton Symphony Orchestra, Saturday, May 30 and taken down on Saturday, June 13, 2026

X. PUBLIC COMMENTS FOR ITEMS NOT ON THE AGENDA

We will now open the meeting for public comment for items not on the agenda. The Mayor and Council will take comments first from members of the public attending the meeting in person, then from members of the public attending the meeting via Zoom. Speakers will be limited to 3 minutes. The Governing Body will use this public comment period as an opportunity to listen to resident concerns, but not to debate issues or engage in a question-and-answer session. Issues raised by members of the public may require review and/or further investigation prior to responding. All comments will be considered and are always welcomed.

IN-PERSON:

Please use the sign-up sheet on the podium. After everyone who signed up has had the opportunity to speak, the Mayor will invite any additional comments from members of the public. Please line up at the podium if you plan to speak. Anyone wishing to make any comments, please state your name and the town you live in for the record.

ZOOM:

To make a comment or ask a question during the meeting via zoom, raise your hand using one of the following alternatives:

1. Windows or Mac platform: Click on “Participants” at the bottom of the screen, then click on “raise hand” (Windows shortcut: Alt+Y; Mac shortcut: Option+Y).
2. Android or iOS device: Click on “raise hand” in the bottom left corner of your screen.
3. Telephone: Press #9

XI. ADJOURNMENT



Municipality of Princeton, NJ

400 Witherspoon St
Princeton, NJ 08540

Staff Report

File #: 0030

Agenda Date: 4/13/2026

Agenda #: 1.

Mayor and Council of Princeton-Closed Session-November 5, 2025

Municipality of Princeton, NJ

*400 Witherspoon St
Princeton, NJ 08540*



Meeting Minutes - Draft

Wednesday, November 5, 2025

3:30 PM

Virtual Meeting

Mayor and Council Closed Session

I. STATEMENT CONCERNING NOTICE OF MEETING

Notice of this meeting was provided in accordance with the requirements of the Open Public Meetings Act and State regulations governing public meetings, including the time, date and location of the meeting and clear and concise instructions to the public for accessing the meeting and making comments. In addition, the agenda and all related materials were posted electronically and made available to the public on Princeton's meeting portal in advance of the meeting.

II. ROLL CALL

Also Present: Bernard Hvozdovic, Administrator; Deanna Stockton, Deputy Administrator/Municipal Engineer; Adam Kooker, Fire Chief; and Robert Merryman, Labor Attorney, Apruzzese, McDermott, Mastro, & Murphy

Present	Leticia Fraga, Mark Freda, Brian McDonald, Leighton Newlin, and Mia Sacks
Absent	David Cohen, and Michelle Pirone Lambros

III. CLOSED SESSION

1. Resolution of the Mayor and Council of Princeton to Enter Closed Session (Open Public Meetings Act Sec.3)

The agenda was amended to change the order discussion. The subjects were discussed in the following order: Contract Negotiations-FMBA; Matters Falling Under the Attorney-Client Privilege: Boards, Commissions & Committees-(BCC's); then, Contract Negotiations-PBA.

RESULT:	ADOPTED
MOVER:	Brian McDonald
SECONDER:	Leticia Fraga
Aye:	Fraga, McDonald, Newlin, and Sacks
Absent:	Cohen, and Pirone Lambros

-Contract Negotiations- PBA

Bernard Hvozdovic, Administrator, provided an update on the status of the terms to be presented to the PBA, including those agreed upon by staff.

Robert Merryman, Labor Attorney from Apruzzese, McDermott, Mastro & Murphy, reviewed the proposed final terms and conditions with Council to confirm their approval prior to presentation to the PBA. He also advised Council on next steps in the negotiation process.

-Contract Negotiations- FMBA

Bernard Hvozdovic, Administrator, provided an overview of the status of negotiations with the FMBA.

Adam Kooker, Fire Chief, delivered a PowerPoint presentation to Council, providing additional information and relevant data for consideration regarding the FMBA negotiations. Following the presentation, Council engaged in a question-and-answer session with Chief Kooker to seek clarification and obtain further information.

Chief Kooker and Councilwoman Michelle Pirone Lambros left the meeting at 4:47 p.m.

-Matters Falling Under the Attorney-Client Privilege: Boards, Commissions & Committees- (BCC's)

Councilman Brian McDonald presented the resume of a potential candidate for appointment to the Princeton Environmental Commission. Council held a discussion regarding the candidate.

IV. ADJOURNMENT

A motion to conclude the Closed Session and return to Open Session was made by Councilman David Cohen, seconded by Councilman Brian McDonald, and carried unanimously by all members present. Then a subsequent motion to adjourn the meeting at 5:12 p.m. was made by Councilman David Cohen, seconded by Councilman Brian McDonald, and carried unanimously by all members present.

Respectfully submitted,

Dawn M. Mount
Municipal Clerk



Municipality of Princeton, NJ

400 Witherspoon St
Princeton, NJ 08540

Staff Report

File #: 0031

Agenda Date: 4/13/2026

Agenda #: 1.

Annual Report on the Center for Modern Aging Princeton- Drew Dyson, PhD, CEO



Municipality of Princeton, NJ

400 Witherspoon St
Princeton, NJ 08540

Staff Report

File #: R-26-119

Agenda Date: 4/13/2026

Agenda #: 1.

Resolution of the Mayor and Council of Princeton Authorizing the Purchase of Firefighter Protective Gear and Equipment from MES for \$63,285.98 utilizing New Jersey State Contracts 25-COMG-131371 and 25-COMG-131390

WHEREAS, the Municipality of Princeton (“Princeton”) wishes to purchase firefighter turn out gear; and

WHEREAS, firefighter protective gear, equipment, and supplies are available on State Contracts 25-COMG-131371 and 25-COMG-131390 awarded by the State of New Jersey, Department of the Treasury, Division of Purchase and Property (“Division”); and

WHEREAS, MES provided a quotation for the desired protective gear and equipment in the amount of \$63,285.98; and

WHEREAS, in accordance with the authority set forth in N.J.S.A. 40A:11-12 of the Local Public Contracts Law, the Municipality of Princeton may, without publicly advertising for bids, purchase any goods or services under any contract for such goods and services entered into on behalf of the Division; and

WHEREAS, the Certified Financial Officer has certified that the Municipality of Princeton has appropriated sufficient funds for this equipment in account 04-215-25-007-052-308.

NOW, THEREFORE, BE IT RESOLVED by the Mayor and Council of the Municipality of Princeton, County of Mercer, State of New Jersey, as follows:

1. The Mayor and Council, or their designee, are hereby authorized and directed to enter into an agreement with MES for firefighter protective gear and equipment for \$63,285.98 without public bidding as permitted by law utilizing New Jersey State Contracts 25-COMG-131371 and 25-COMG-131390.
2. A copy of this Resolution and the contract will be kept on file in the Office of the Clerk.



(856) 488-4499

Quote

Quote # QT2049980
Date 03/20/2026
Expires 04/30/2026
Sales Rep Watson, Frank
PO # 2026 Gear
Shipping Method FedEx Ground
Customer PRINCETON FIRE DEPT (NJ)
Customer # C34392

Bill To

PRINCETON FIRE DEPT
 Afroula Ippolito
 363 Witherspoon Street
 PRINCETON NJ 08540
 United States

Ship To

STATION 60
 PRINCETON FIRE DEPT
 363 Witherspoon Street
 Princeton NJ 08542
 United States

Item	Alt. Item #	Units	Description	QTY	Unit Price	Amount
HFRP Tail Coat	Specid NJPTON00043		Specid NJPTON00043 HFRP Tail Coat Honeywell Morningpride Tails Coat with all the specs per Princeton Fire Department Velcro/Zipper Closure List Price \$3583.45 1- REVY 2- NEGUERUELA 3- ESMERADO 4- WALKER 5- ONOFRE	5	\$2,544.25	\$12,721.25
HFRP Tail Coat	Specid NJPTON00046		Specid NJPTON00046 HFRP Tail Coat Morningpride Tails Coat with all the specs per Princeton Fire Department Hook and Dee Closure List Price \$3624.54 1- M. LUCK 2- SZYSZKO 3- GOLOMB 4- SITEK 5- SARETT 6- TOMALIN	6	\$2,573.42	\$15,440.52
HFRP Tail Pant	Specid NJPTON00044		Specid NJPTON00044 HFRP Tail Pant ** Pro Fit Pant** Honeywell Morningpride Pro fit pant with all the specs per Princeton Fire Department 1- ESMERADO 2- GOLOMB 3- WALKER List Price \$2,758.37	3	\$1,958.44	\$5,875.32



QT2049980



(856) 488-4499

Quote

Quote # QT2049980
 Date 03/20/2026

Item	Alt. Item #	Units	Description	QTY	Unit Price	Amount
HFRP Tail Pant	Specid NJPTON00045		Specid NJPTON00045 HFRP Tail Pant Honeywell Morningpride LTO pant with all the specs per Princeton Fire Department List Price \$2,811.79 1- REVY 2- NEGUERUELA 3- TOMALIN 4- M. LUCK 5- SZYSZKO 6- SITEK 7-SARETT 8- ONOFRE	8	\$1,996.37	\$15,970.96
BT5007-Black-8.5-E			Honeywell Pro-Warrington Leather Structural Boot-NFPA - *NEEDS QUICK QUOTE* List Price \$833.07	1	\$541.49	\$541.49
BT5007-Black-9.5-E			Honeywell Pro-Warrington Leather Structural Boot-NFPA - *NEEDS QUICK QUOTE* List Price \$833.07	1	\$541.49	\$541.49
BT5007-Black-10-E			Honeywell Pro-Warrington Leather Structural Boot-NFPA - *NEEDS QUICK QUOTE* List Price \$833.07	3	\$541.49	\$1,624.47
BT5007-Black-10.5-E			Honeywell Pro-Warrington Leather Structural Boot-NFPA - *NEEDS QUICK QUOTE* List Price \$833.07	3	\$541.49	\$1,624.47
BT5007-Black-11.5-E			Honeywell Pro-Warrington Leather Structural Boot-NFPA - *NEEDS QUICK QUOTE* List Price \$833.07	1	\$541.49	\$541.49
BT5007-Black-13-E			Honeywell Pro-Warrington Leather Structural Boot-NFPA - *NEEDS QUICK QUOTE* List Price \$833.07	1	\$541.49	\$541.49
BT5007-Black-7.5-E			Honeywell Pro-Warrington Leather Structural Boot-NFPA - *NEEDS QUICK QUOTE* List Price \$833.07	1	\$541.49	\$541.49
HFRP Helmet	MES002002254831 4360		MES0020022548314360 Honeywell Helmet Ben II LR Helmet Black List Price \$587.31	10	\$381.75	\$3,817.50
MES-Excalibur-Small-Regular			MES-Excalibur Gauntlet Glove List Price \$130.00	5	\$112.97	\$564.85
MES-Excalibur-Large-Regular			MES-Excalibur Gauntlet Glove List Price \$130.00	5	\$112.97	\$564.85
MES-Excalibur-Medium-Regular			MES-Excalibur Gauntlet Glove List Price \$130.00	5	\$112.97	\$564.85
MES-Excalibur-X-large-Regular			MES-Excalibur Gauntlet Glove List Price \$130.00	3	\$112.97	\$338.91
MES-Excalibur-2X-Large-Regular			MES-Excalibur Gauntlet Glove List Price \$130.00	2	\$112.97	\$225.94



QT2049980



(856) 488-4499

Quote

Quote # QT2049980
Date 03/20/2026

Item	Alt. Item #	Units	Description	QTY	Unit Price	Amount
39708-00-192198			BarriAire Carbon (black) Shield Elite Pro Comprehensive Coverage - Extends Particulate Barrier coverage beyond critical areas as identified by NFPA - Maximum Protection List Price \$169.95	8	\$155.58	\$1,244.64

NJ State Contract 25-COMG-131371 Morningpride
MES NJ State Contract 25-COMG-131390 Firecraft, PGI

Subtotal	\$63,285.98
Shipping Cost	\$0.00
Tax Total	\$0.00
Total	\$63,285.98

Quote # NJ24614NJPTON
Specid NJPTON00043
Specid NJPTON00044
Specid NJPTON00045
Specid NJPTON00046

Quote #22548314
MES0020022548314360

Quotation 22554088
BT5007

Contact: C34392 PRINCETON FIRE DEPT (NJ) : Afroula Ippolito (609) 497-7646

This Quotation is subject to any applicable sales tax and shipping and handling charges that may apply. Tax and shipping charges are considered estimated and will be recalculated at the time of shipment to ensure they take into account the most current information.

All returns must be processed within 30 days of receipt and require a return authorization number and are subject to a restocking fee.

Custom orders are not returnable. Effective tax rate will be applicable at the time of invoice.



QT2049980



Municipality of Princeton, NJ

400 Witherspoon St
Princeton, NJ 08540

Staff Report

File #: R-26-120

Agenda Date: 4/13/2026

Agenda #: 2.

Resolution of the Mayor and Council of Princeton Authorizing an Increase of \$6,500.00 to the Not to Exceed Amount for the Professional Services Agreement with PS&S, LLC for Professional Engineering Services in Connection with the Terhune Road Pedestrian Improvements Project for a New Not to Exceed Amount of \$185,000.00

WHEREAS, by Resolution 24-238 adopted on August 12, 2024, Council awarded a contract to PS&S, LLC for professional engineering services in connection with the Terhune Road Pedestrian Improvement project for an amount not to exceed \$143,000.00 with the anticipated completion date of April 30, 2026; and

WHEREAS, by Resolution 25-143 adopted on April 14, 2025, Council authorized an increase of \$10,500.00 for a new not to exceed amount of \$153,500.00; and

WHEREAS, by Resolution 25-233 adopted on July 14, 2025, Council authorized an increase of \$25,000.00 for a new not to exceed amount of \$178,500.00; and

WHEREAS, additional engineering services will be needed that were not part of the original contract; and

WHEREAS, it is recommended to increase the current contract amount by \$6,500.00 for a new not to exceed amount of \$185,000.00; and

WHEREAS, the Chief Financial Officer has certified that sufficient funds are available to pay for said services from 04-215-23-021-076-331.

NOW, THEREFORE, BE IT RESOLVED by the Council of Princeton, County of Mercer, State of New Jersey, as follows:

1. The Mayor and Council, or their designee, hereby authorize the amendment to the professional services agreement originally authorized by Resolution 24-238 on August 12, 2024, and amended by Resolution 25-143 on April 14, 2025, and amended by Resolution 25-233 on July 14, 2025, between Princeton and PS&S, LLC for Professional Engineering Services in Connection with the Terhune Road Pedestrian Improvement Project to increase the not to exceed amount by \$6,500.00 for a new not to exceed amount of \$185,000.00.
2. All remaining provisions of the original agreement not otherwise amended by or inconsistent herewith shall remain in full force and effect.
3. This Resolution, when countersigned by PS&S, LLC, shall serve as the third amendment to the original agreement.



MUNICIPALITY OF PRINCETON

Department of Infrastructure
& Operations

400 Witherspoon Street

Princeton, NJ 08540

(609) 921-7077

engineering@princetonnj.gov

MEMORANDUM

To: Mayor and Council
From: Deanna Stockton, PE, CME, *Deputy Administrator*
James J. Purcell, PE, *Assistant Municipal Engineer*
Subject: Amendment to the Professional Services Agreement with PS&S for the Terhune Road Safe Streets to Transit Pedestrian Improvement Project
Date: April 10, 2026

Attached for Council's consideration at its April 13, 2026 meeting is an amendment to PS&S' professional services agreement to design pedestrian improvements on Terhune Road between Mount Lucas Road and North Harrison Street.

This project will replace existing sidewalks and add missing sidewalks on Terhune Road between North Harrison Street and Mount Lucas Road. The original consultant design scope of work focused solely on the sidewalk design and permitting. An earlier amendment added design of new curbing due to the deteriorated condition of much of the existing curbing, and to include raised intersection tables for traffic calming along the corridor.

Over the last two years, as design has progressed, the existing pavement has deteriorated from a state of good repair to one of fair condition. When the curb replacement and raised intersection installation occurs, additional joints will be introduced into the pavement section. While these joints are sealed, they introduce a potential pathway for water and its related expansion/contraction cycles to further deteriorate the pavement by causing surface failures. Consequently, Engineering recommends that Terhune Road be milled and resurfaced as part of this project. Adding the milling and resurfacing to the project should allow for a more economical and more timely pavement restoration than waiting until this project was completed and bidding the work separately. While NJDOT has awarded a grant for \$1,000,000 for the portion of the work associated with the sidewalks, this resurfacing is not eligible for reimbursement. Consequently, the resurfacing work will be bid as an alternate.

Engineering recommends approval of the additional \$6,500.00 in professional services fees for the preparation of construction contract documents for the milling and resurfacing of Terhune Road as part of the Terhune Road Safe Streets to Transit Pedestrian Improvement Project.

Please contact me if you have any questions.



1450 State Route 34
 Wall, NJ 07753
 732.363.5850

Scope Change Authorization

PS&S Author: Mark Cifelli
 Client: Municipality of Princeton
 Project Title: Terhune Road Pedestrian Improvements

Date: 3/31/26
 PS&S Project No.: 055440002
 Contract Reference: 9/16/24 Contract

Amendment No.: 3

Reason for Scope Change: Engineering services to add road resurfacing plans to the set

Requested by: Mark Cifelli

Description of Services: See attached scope of work

Effect on Schedule: _____

Estimated Personnel Hours:

0A Architectural	_____	04 Environmental	_____	08 Electrical	_____
01 Structural	_____	05 Mechanical	_____	09 Project Mgmt	_____
02 Civil	<u>x</u>	06 Sanitary Facilities	_____	10 Project Controls	_____
	_____	07 Survey	_____	05 Process Eng	_____
				Other	_____

Total Hours: _____
 Total Labor Fee: \$ 6,500.00
 Reimbursable Expenses: \$ As Incurred
 Total Fee Estimate: \$ 6,500.00

Authorization:	
Company Name:	_____
Owner/Client Rep:	_____
Signature:	_____
Date Approved:	_____

(Six Thousand Five Hundred Dollars)

Contract Fee Status:
 Original Amount: \$ 143,000
 Prior Amendments: \$ 35,500
 This Amendment: \$ 6,500
 Revised Total: \$ 185,000

cc: _____

PROJECT DESCRIPTION

The initial scope of services for the Terhune Road Pedestrian Improvement project included new and replacement sidewalks, curb ramps and driveway aprons along Terhune Road, with associated stormwater management and permitting. After preliminary design of these improvements, we were previously informed that the Municipality wanted to add new curbing to the project, and more recently that (3) three raised intersections would be added.

SCOPE OF SERVICES

Phase 1 – Initial Resurfacing Concept

During preparation of the Pedestrian Improvement Plans we were previously asked to include resurfacing of Terhune Road for the project area. We depicted the area of milling and repaving on the plans previously along with quantities and estimated costs.

Lump Sum - \$900.00

Phase 2 – Roadway Resurfacing Plans

PS&S will prepare a separate set of plans to be attached to the Pedestrian Improvement Plans. The plans will include the following:

1. Construction Plan – a separate construction plan depicting the project area, limits of road resurfacing, resetting of utility structure rims/covers, and road striping. Quantities will be tabulated on each sheet.
2. Construction Details – addition of resurfacing details, as well as road striping details
3. Detour Plan – Updates to show detour routes for road closures for resurfacing
4. EDQ – The EDQ will be updated to add items relating to the resurfacing

Lump Sum - \$4,400.00

Phase 3 – Meetings

The initial contract for this project included (3) meetings with the Township. A 4th meeting to review the plans was attended on 2/10/26, and we were asked to attend the DRCC meeting which we attended virtually. We would request that the budget for the meetings phase be increased by \$1,200 to cover this additional meeting time. Should any additional meetings be required after acceptance of this scope change a separate scope change would be required.

Lump Sum - \$1,200.00

ADDITIONAL INFORMATION REQUESTED

Survey for this project was provided by Princeton. The location and rim elevation of any utility structures in the roadway should be confirmed by Princeton's survey team and provided as updates to the base map prior to completion of these roadway resurfacing plans.



Municipality of Princeton, NJ

400 Witherspoon St
Princeton, NJ 08540

Staff Report

File #: R-26-121

Agenda Date: 4/13/2026

Agenda #: 3.

Resolution of the Mayor and Council of Princeton Authorizing the Award of a Professional Services Agreement to One Water Consulting LLC for a Watershed Assessment Report for an Amount Not to Exceed \$29,700.00

WHEREAS, the Municipality of Princeton has a need for a Watershed Assessment Report; and

WHEREAS, One Water Consulting LLC provided a proposal for these services for an amount not to exceed \$29,700.00; and

WHEREAS, pursuant to N.J.S.A. 40A:11-5(1)(a)(i) of the Local Public Contracts Law, Princeton may award a contract for professional services without public advertising for bids; and

WHEREAS, this contract is not being awarded as a “fair and open” contract as defined in N.J.S.A. 19:44A-20.7; and

WHEREAS, pursuant to N.J.S.A. 19:44A-20.5., the Municipality of Princeton may award a non-fair and open contract to a business entity if, during the preceding one-year period, that business entity has not made a contribution that is reportable by the recipient under P.L. 1973, c.83, N.J.S.A. 19:44A-1 et seq. to any municipal committee of a political party in that municipality if a member of that political party is serving in an elective public office of that municipality when the contract is awarded or to any candidate committee of any person serving in an elective public office of that municipality when the contract is awarded; and

WHEREAS, One Water Consulting LLC has completed and submitted the required pay-to-play forms which certify that One Water Consulting LLC has not made any reportable contributions to a candidate committee in the Municipality of Princeton in the previous year, and that the contract will prohibit One Water Consulting LLC from making any reportable contributions through the term of the contract; and

WHEREAS, the Certified Financial Officer has certified that the Municipality of Princeton has appropriated sufficient funds for these services in account 04-215-24-014-076-335; and

WHEREAS, the term of this contract shall be twelve months.

NOW, THEREFORE, BE IT RESOLVED by the Mayor and Council of the Municipality of Princeton, County of Mercer, State of New Jersey, as follows:

1. The Mayor and Council, or their designee, are hereby authorized and directed to enter into an agreement with One Water Consulting LLC for a Watershed Assessment Report for an amount not to exceed \$29,700.00 without competitive bidding as a Professional Service in accordance with N.J.S.A. 40A:11-5(1)(a)(i).

2. The Term of this contract shall be twelve months.
3. A copy of this Resolution, Pay-to-Play Forms, and contract will be kept on file in the Office of the Clerk.



MUNICIPALITY OF PRINCETON

Department of Infrastructure & Operations

400 Witherspoon Street

Princeton, NJ 08540

(609) 921-7077

engineering@princetonnj.gov

MEMORANDUM

To: Mayor and Council
From: Deanna Stockton, *Deputy Administrator*
Subject: Professional Services Agreement with One Water Consulting, LLC for Services Related to a Watershed Improvement Plan
Date: April 8, 2025

Attached for authorization by Princeton Mayor and Council at its April 13, 2026 meeting are a resolution and professional services agreement with One Water Consulting for work related to a Watershed Improvement Plan.

With the new municipal separate storm sewer system (MS4) regulations that were made effective by the New Jersey Department of Environmental Protection (NJDEP) on January 1, 2023, municipalities are subject to a new regulation to create a Watershed Improvement Plan (WIP), over 3 phases, for each of their HUC-14 watersheds. The first component of the WIP, called the Watershed Inventory Report (WIR), was completed in accordance with NJDEP’s deadline at the end of 2025. The second of three WIP documents to be completed by January 1, 2027 is the Watershed Assessment Report (WAR). The final document to complete the WIP is due by December 1, 2027.

There are eight HUC-14 watersheds within Princeton:

Hydrologic Unit Code (14 Digit)	Sub-Watershed Name
2030105110050	Beden Brook (below Province Line Rd)
2030105090080	Duck Pond Run
2030105110030	Millstone R (Beden Bk to Heathcote Bk)
2030105110020	Millstone R (HeathcoteBk to Harrison St)
2030105090070	Stony Bk (Alexander Crk to Rt 206)
2030105090090	Stony Bk (Princeton)
2030105090060	Stony Bk (Rt 206 to Province Line Rd)
2030105090050	Stony Bk(Province Line Rd to 74d46m dam)

As watershed boundaries do not follow municipal or county boundaries necessarily, Princeton has adopted a regional planning approach for those watersheds, including the Stony Brook and Lower Millstone watersheds, which extend beyond the municipal border. One Water Consulting is the firm that is working on those watershed assessments. But there are other watersheds completely within Princeton which must be addressed. In order to complete Princeton’s WAR for all of its HUC-14 watersheds, One Water Consulting has provided the attached proposal to perform the following tasks:

1. Summary of Sub-Watershed Assessments such as general watershed characteristics, flooding, impairments, hydrology, and impervious coverage.
2. Mapping Support to supplement Princeton’s interactive GIS WIR map currently available at <https://experience.arcgis.com/experience/82dbcd9ea2a940c9b9d52f7ee27aeaef>.
3. Identification of Potential Improvement Projects to address the impairments, flooding, and other watershed issues identified in task 1.

4. Implementation Schedule and Funding Needs. Note, NJDEP does not currently have a defined schedule for which municipalities must complete the potential improvement projects. One Water will structure the implementation schedule with short-term (0-5 years), mid-term (5-10 years), and long-term (10-20 years) goals.
5. Public Involvement and Feedback including one public meeting.
6. Watershed Assessment Report Deliverable for submittal to NJDEP.

The total contract amount to complete this scope of work is \$29,700.

We appreciate Council's authorization of this contract, which is necessary for Princeton to remain compliant with its MS4 permit requirements. Please contact me if you have any questions.

**PROFESSIONAL SERVICES AGREEMENT FOR A WATERSHED ASSESSMENT
REPORT**

THIS AGREEMENT (“Agreement” or “agreement”) is by and between THE MUNICIPALITY OF PRINCETON (“PRINCETON”), a municipal corporation of the state of New Jersey, 400 Witherspoon Street, Princeton, New Jersey, 08540 (hereinafter referred to as "PRINCETON") and ONE WATER CONSULTING LLC, 100 Poor Farm Rd, 2nd Floor, Princeton, New Jersey 08540 (hereinafter referred to as "CONSULTANT".)

WITNESS

WHEREAS, PRINCETON desires to obtain a Watershed Assessment Report; and

WHEREAS, on February 16, 2026, CONSULTANT provided a written proposal to PRINCETON for purposes of performing the sought-after professional services to PRINCETON, a copy of which is attached as Exhibit B hereto; and

WHEREAS, by resolution, the Council awarded an agreement for professional services to CONSULTANT without public bidding as authorized by law, in accordance with the provisions of the Local Public Contracts Law, N.J.S.A. 40A:11-1 et seq.

NOW THEREFORE, IT IS AGREED by and between PRINCETON and CONSULTANT as follows:

1. Scope of Services.

- a. In consideration for payment of the cost set forth in Section 3 below, CONSULTANT shall use its best efforts to perform professional services and other related duties as set forth in the CONSULTANT’S proposal, a copy of which is attached hereto as Exhibit B and incorporated herein as if fully restated. Should there be any conflict between the terms of CONSULTANT’S proposal and this Agreement, the terms of this Agreement shall control.

2. Contract Term.

- a. This Agreement shall become effective upon the date of the final signature below.
- b. This Agreement shall expire twelve months from the effective date, unless terminated sooner pursuant to the termination provisions set forth in subsection 2c. below.
- c. The Agreement may be terminated by either party, by giving thirty (30) days advanced written notice to the other, to the address as set forth on page 1 above.

3. Compensation; Manner of Payment.

- a. The anticipated cost of CONSULTANT’S services as described herein shall not exceed twenty-nine thousand, seven hundred dollars and zero cents (\$29,700.00), subject to annual budgetary appropriations.

- b. CONSULTANT shall bill PRINCETON monthly on municipal vouchers for services rendered and reimbursement for such expenses incurred during the prior month, based on the hourly rates and fees set forth in Exhibit B. CONSULTANT shall give written notice to PRINCETON when the CONSULTANT has billed eighty percent (80%) of the compensation set forth in paragraph 3a.
- c. PRINCETON agrees to pay CONSULTANT within thirty (30) days of receipt of invoice and an audited and approved signed voucher.

4. Terms and Conditions.

- a. CONSULTANT shall take note of and comply with the requirements of N.J.S.A. 10:5-31 et seq. and N.J.A.C. 17:27 regarding Affirmative Action/ Equal Employment Opportunity and the Americans with Disabilities Act. The parties hereby incorporate into this Agreement the Affirmative Action/Non-Discrimination addendum per the attached Exhibit A.
- b. CONSULTANT shall take note of and comply with the requirements of P.L. 2004, c.57 (N.J.S.A. 52:32-44 et seq.) regarding Business Registration and Sales and Use Tax. The parties hereby incorporate into this Agreement the Business Registration and Sales and Use Tax addendum per the attached Exhibit C.
- c. The Terms and Conditions printed on the purchase order issued by PRINCETON to CONSULTANT shall be incorporated into this agreement per the attached Exhibit D.

5. Political Contributions.

- a. This Agreement has been awarded to CONSULTANT based on the merits and abilities of CONSULTANT to provide the services as described herein. This Agreement was not awarded through a “fair and open process” as that phrase is defined in N.J.S.A. 19:44A-20.7. As such, CONSULTANT hereby certifies that CONSULTANT (including persons and other business entities having an interest in CONSULTANT, as defined by N.J.S.A. 19:44A-20.7) has neither made a contribution that is reportable by the recipient under P.L. 1973, c.83, N.J.S.A. 19:44A-1 et seq. (i.e., in excess of \$200.00), in the one (1) year period preceding the award of this Agreement nor will it make a reportable contribution during the term of this Agreement to any municipal committee of a political party if a member of that political party is serving in an elective public office of the municipality of PRINCETON when the Agreement is awarded, or to any candidate committee of any person serving in an elective public office of the municipality of PRINCETON when the Agreement is awarded.
- b. CONSULTANT is advised of the responsibility to file an annual disclosure statement on political contributions with the New Jersey Election Law Enforcement Commission (ELEC) pursuant to N.J.S.A. 19:44A-20.27 if CONSULTANT receives in a calendar year \$50,000 or more in the aggregate through agreements or contracts with a public entity. It is CONSULTANT’S responsibility to determine if filing is necessary. Additional information on this requirement is available from ELEC at (888) 313-3532 or www.elec.state.nj.us.

6. Insurance; Hold Harmless.

- a. Prior to commencing work, CONSULTANT shall furnish PRINCETON with a Certificate of Insurance as evidence that it has procured such commercial, automobile, workers' compensation, employer's and professional liability insurance coverage as is customary for the type and scope of services to be rendered under this Agreement. PRINCETON, and its officers, employees, agents and consultants, shall be listed as additional insured and as the certificate holder on such policies.
- b. CONSULTANT shall defend, indemnify and hold harmless PRINCETON, its officers, employees, agents and consultants from any and all claims, suits, actions, damages or costs, of any nature whatsoever, whether for personal injury, property damage or other liability, arising out of or in any way connected with the CONSULTANT'S acts or omissions, or those of its officers, employees, agents and consultants, in connection with this Agreement.
- c. It is also agreed that the acceptance of the final payment by the CONSULTANT shall be considered as a release in full of all claims against PRINCETON arising out of or by reason of performance or non-performance of the CONSULTANT'S obligations under this contract.

7. Complete Agreement.

- a. This Agreement and any attachments hereto or incorporated by reference represents the entire contract between the parties and shall take precedence over all other prior or existing understandings or agreements, if any, whether oral or written.

IN WITNESS WHEREOF, the parties have set their hand and seal the day and date first written above.

ATTEST:

THE MUNICIPALITY OF PRINCETON

By: _____
Dawn M. Mount, Municipal Clerk

By: _____
Mark Freda, Mayor

Date: _____

Date: _____

WITNESS:

ONE WATER CONSULTING LLC

By: _____

By: _____
Authorized Representative

Date: _____

Date: _____

EXHIBIT A

MANDATORY EQUAL EMPLOYMENT OPPORTUNITY LANGUAGE N.J.S.A. 10:5-31 et seq. (P.L. 1975, c. 127) N.J.A.C. 17:27 et seq.

GOODS, GENERAL SERVICE AND PROFESSIONAL SERVICES CONTRACTS

During the performance of this contract, the contractor agrees as follows:

The contractor or subcontractor, where applicable, will not discriminate against any employee or applicant for employment because of age, race, creed, color, national origin, ancestry, marital status, affectional or sexual orientation, gender identity or expression, disability, nationality or sex. Except with respect to affectional or sexual orientation and gender identity or expression, the contractor will ensure that equal employment opportunity is afforded to such applicants in recruitment and employment, and that employees are treated during employment, without regard to their age, race, creed, color, national origin, ancestry, marital status, affectional or sexual orientation, gender identity or expression, disability, nationality or sex. Such equal employment opportunity shall include, but not be limited to the following: employment, upgrading, demotion, or transfer; recruitment or recruitment advertising; layoff or termination; rates of pay or other forms of compensation; and selection for training, including apprenticeship. The contractor agrees to post in conspicuous places, available to employees and applicants for employment, notices to be provided by the Public Agency Compliance Officer setting forth provisions of this nondiscrimination clause.

The contractor or subcontractor, where applicable will, in all solicitations or advertisements for employees placed by or on behalf of the contractor, state that all qualified applicants will receive consideration for employment without regard to age, race, creed, color, national origin, ancestry, marital status, affectional or sexual orientation, gender identity or expression, disability, nationality or sex.

The contractor or subcontractor will send to each labor union, with which it has a collective bargaining agreement, a notice, to be provided by the agency contracting officer, advising the labor union of the contractor's commitments under this chapter and shall post copies of the notice in conspicuous places available to employees and applicants for employment.

The contractor or subcontractor, where applicable, agrees to comply with any regulations promulgated by the Treasurer pursuant to N.J.S.A. 10:5-31 et seq., as amended and supplemented from time to time and the Americans with Disabilities Act.

The contractor or subcontractor agrees to make good faith efforts to meet targeted county employment goals established in accordance with N.J.A.C. 17:27-5.2.

The contractor or subcontractor agrees to inform in writing its appropriate recruitment agencies including, but not limited to, employment agencies, placement bureaus, colleges, universities, and labor unions, that it does not discriminate on the basis of age, race, creed, color, national origin, ancestry, marital status, affectional or sexual orientation, gender identity or expression, disability, nationality or sex, and that it will discontinue the use of any recruitment agency which engages in direct or indirect discriminatory practices.

The contractor or subcontractor agrees to revise any of its testing procedures, if necessary, to assure that all personnel testing conforms with the principles of job related testing, as established by the statutes and court decisions of the State of New Jersey and as established by applicable Federal law and applicable Federal court decisions.

In conforming with the targeted employment goals, the contractor or subcontractor agrees to review all procedures relating to transfer, upgrading, downgrading and layoff to ensure that all such actions are taken without regard to age, race, creed, color, national origin, ancestry, marital status, affectional or sexual orientation, gender identity or expression, disability, nationality or sex, consistent with the statutes and court decisions of the State of New Jersey, and applicable Federal law and applicable Federal court decisions.

The contractor shall submit to the public agency, after notification of award but prior to execution of a goods and services contract, one of the following three documents:

Letter of Federal Affirmative Action Plan Approval;

Certificate of Employee Information Report; or

Employee Information Report Form AA302 (electronically provided by the Division and distributed to the public agency through the Division's website at http://www.state.nj.us/treasury/contract_compliance).

The contractor and its subcontractors shall furnish such reports or other documents to the Division of Purchase and Property, CCAU, EEO Monitoring Program as may be requested by the office from time to time in order to carry out the purposes of these regulations, and public agencies shall furnish such information as may be requested by the Division of Purchase and Property, CCAU, EEO Monitoring Program for conducting a compliance investigation pursuant to **N.J.A.C. 17:27-1 et seq.**

EXHIBIT B



February 16, 2026

VIA EMAIL

Deanna Stockton
Municipal Engineer / Deputy Administrator
Department of Infrastructure & Operations
Municipality of Princeton
400 Witherspoon Street
Princeton, NJ 08540

**RE: WATERSHED ASSESSMENT REPORT
MUNICIPALITY OF PRINCETON MS4 PERMIT**

Dear Deanna:

As requested, we have prepared this proposal to assist the Municipality of Princeton with preparation of the Watershed Assessment Report (WAR) as required by its Municipal Separate Storm Sewer System (MS4) Permit and associated Watershed Improvement Plan. Background information is presented below followed by our proposed Scope of Work and Cost Proposal.

BACKGROUND INFORMATION

The new MS4 permit became effective on January 1, 2023 with a new requirement for the development of a Watershed Improvement Plan, which encourages municipalities to shift towards watershed level planning for stormwater management.

The requirements of the Watershed Improvement Plan are spread over five years with three deliverables. The first deliverable, the Watershed Inventory Report (WIR), was prepared for the Municipality of Princeton on December 31, 2025. The WIR summarizes and presents the various data collection and mapping requirements related to the various stormwater outfalls and subwatersheds in the municipality.

The WAR is the second deliverable, due by the end of 2026, and includes a subwatershed specific assessment, a summary of potential improvement projects, identification of funding needs and potential sources, and an estimated implementation schedule.

One Water is currently working on the Stony Brook Watershed Management Plan and the Lower Millstone Watershed Management Plan. The work on these Plans will provide the majority of technical information needed to complete the WAR for Princeton.

The Scope of Services for preparation of the WAR is presented below.

SCOPE OF SERVICES

One Water will prepare the MS4 Permit WAR. As noted above, this is the second deliverable in the Watershed Improvement Plan which is due by the end of 2026. The WAR will rely on data and mapping collected as part of the WIR as well as the regional Watershed Management Plans being developed by One Water for the Stony Brook and Lower Millstone Watersheds. The following tasks will be completed as part of the preparation of the WAR.

Task 1 – Summary of Subwatershed Assessments

One Water will develop a summary of the Princeton subwatershed assessments prepared as part of the Stony Brook and Lower Millstone Watershed Management Plans for inclusion in the WAR. The summary will include the general characteristics of the watershed including geology and geomorphology, climate, hydrologic conditions, existing stormwater improvement projects, and a summary of existing watershed-based plans and TMDLs. The summary will also include a list of impaired waterbodies, impairment/TMDL parameters and goals, areas prone to flooding, land cover/land use patterns, soil characteristics, and potential sources of pollution. In addition, One Water will prepare subwatershed assessments for the direct Carnegie Lake subwatersheds that are not included within the Stony Brook or Lower Millstone watersheds.

Task 2 – Mapping Support

GIS mapping is an important component of the subwatershed specific assessments. The majority of the required GIS has already been conducted as part of the Watershed Inventory Report or will be conducted as part of the Stony Brook and Lower Millstone Watershed Management Plans. One Water will work with Princeton's GIS professionals and provide additional support as necessary to prepare mapping for the Watershed Assessment Report deliverable. Note that based on draft guidance, it is expected that NJDEP will accept the GIS data as part of the interactive GIS map hosted on Princeton's dedicated stormwater webpage.

Task 3 – Identification of Potential Improvement Projects

One Water will develop a roster of potential improvement projects within the Municipality. The potential projects will be developed from previous plans (i.e. The Watershed Institute Impervious Cover Assessment and Reduction Action Plan) as well as the Stony Brook and Lower Millstone Watershed Management Plans. Projects will also be identified within the direct Carnegie Lake watershed. The project types are anticipated to include both structural BMPs and non-structural/source control elements. In addition, retrofits to existing stormwater infrastructure will be recommended.

Task 4 – Implementation Schedule and Funding Needs

An implementation framework will be developed for the potential improvement projects with an associated schedule and approximate funding needs. While NJDEP does not specify an overall timeframe, we expect that the plan will be divided into near term (0-5 years), mid term (5-10 years) and long term (10-20 years) phases. In addition, the implementation schedule will incorporate periodic monitoring and reevaluation to determine success and to identify additional projects and action items.

Task 5 – Public Involvement and Feedback Support

The WAR requires public involvement and feedback regarding the development of the overall Watershed Improvement Plan. One Water will support Princeton in developing an overall outreach plan for the project. Public engagement sessions from the Stony Brook and Lower Millstone Watershed Management Plans will be documented. We have also assumed that One Water staff will attend one public meeting for Princeton to discuss the development of the WAR.

Task 6 –Watershed Assessment Report Deliverable

One Water will summarize the work performed in Tasks 1 through 5 in a draft WAR deliverable to NJDEP. The document will be prepared in accordance with NJDEP guidelines and first submitted to Princeton for review. We will revise the document based on Princeton’s review and then submit to NJDEP for review and approval. The WAR will serve as the basis for the final Watershed Improvement Plan to be developed and submitted to NJDEP in 2027.

COST PROPOSAL

We will perform all work on a time plus expenses basis in accordance with the enclosed Hourly Billing Rate Schedule and Professional Services Agreement. We recommend establishing a \$29,700 budget for this work. A cost breakdown by task is presented below.

Task 1 – Summary of Subwatershed Assessments:	\$3,400
Task 2 – Mapping Support:	\$2,000
Task 3 – Identification of Potential Improvement Projects:	\$4,200
Task 4 – Implementation Schedule and Funding Needs:	\$4,500
Task 5 – Public Involvement and Feedback Support:	\$6,000
<u>Task 6 – Watershed Assessment Report Deliverable:</u>	<u>\$9,600</u>
Total	\$29,700

If you would like to retain us for these services, please have an authorized representative indicate acceptance of this proposal by signing the agreement and returning a copy to me.

We look forward to assisting you with this project. If you have any questions, you can me via telephone at 609-808-2022 or via e-mail at JCosgrove@OneWaterNJ.com.

Sincerely,



James F. Cosgrove, Jr., P.E.
President



HOURLY BILLING RATES

<u>Category</u>	<u>Rate</u>
James F. Cosgrove, Jr., P.E., President	\$325
Brian J. Friedlich, P.E., Managing Engineer	\$275
Joseph W. Schwarz, P.E., Senior Project Engineer	\$175
Caitlin M. Gilvey, EIT, Staff Engineer	\$155
Erin R. Caputo, EIT, Staff Engineer	\$135
Megan M. Ulozas, Assistant Engineer	\$115
Technical / Project Assistant	\$105

Billing rates are subject to increase during each year. Project related expenses including travel, rental vehicles and equipment, computer charges, safety equipment, disposal of waste materials, telephone charges, messenger and delivery charges, printing, and expendable supplies acquired specifically for the project will be billed at cost. Use of One Water owned vehicles or personal vehicles will be billed at the current IRS Standard Mileage Rate. Fees for subcontractors retained by One Water specifically for the project and on behalf of the client will be billed at cost plus ten percent.

PROFESSIONAL SERVICES AGREEMENT

This Agreement is made on: _____ between the Municipality of Princeton (Client) and One Water Consulting LLC (“One Water” or “OWC”). Client hereby appoints One Water to provide certain Services (as defined below), and One Water hereby agrees to perform the Services, on the following terms and conditions:

1. SCOPE OF SERVICES

Client engages One Water to provide, and One Water agrees to provide, the professional services as set forth in One Water’s Proposal dated February 16, 2026 (Proposal), and as follows (collectively the Services):

One Water will complete a Watershed Assessment Report for the Municipality of Princeton.

SCHEDULE AND PAYMENT

One Water shall perform the Services, and Client shall pay One Water, in accordance with the schedule and payment basis set forth in the Proposal, and as follows:

Work to be invoiced on a time-plus-expenses basis with monthly statements provided to client.

2. GENERAL CONDITIONS AND ADDENDA

Client and One Water have read, understand and agree to this Agreement, the General Conditions, the Indemnity and Limitation of Liability provisions located on Page 2, and all Proposal, Fee Schedule and addenda identified herein.

This Agreement includes the terms herein, General Conditions and any Proposal, Fee Schedule and addenda identified herein, which taken together apply to all services undertaken pursuant to this Agreement, represent the parties’ entire agreement of and supersedes all agreements on the same subjects between the parties, either oral or in writing, including any Client work or purchase order.

This Agreement is governed and construed in accordance with the laws of the state where the Services are performed. The parties irrevocably and unconditionally submit to the non-exclusive jurisdiction of the courts of such state and waive any right to object to any proceedings being brought in those courts. The parties hereby expressly waive any and all rights to trial by jury.

EXECUTED by the parties as of the date first written above:

CLIENT:

ONE WATER CONSULTING LLC:

By: _____

By:  _____

Printed Name: _____

Printed Name: James F. Cosgrove, Jr., P.E.

Title: _____

Title: President

PROFESSIONAL SERVICES AGREEMENT – GENERAL CONDITIONS

1. Standard of Care. OWC will perform its Services in a manner consistent with that level of care and skill ordinarily exercised by other members of OWC's profession practicing in the same locality, under similar conditions and at the date the Services are provided. OWC makes no representation, guarantee or warranty, express or implied, regarding the Services, or any communication (oral or written), certification, report, opinion, or Instrument of Service provided under or pursuant to this Agreement.
2. Insurance. OWC will maintain worker's compensation, commercial general liability, automobile liability and professional indemnity insurance coverage. Client will maintain adequate insurance coverage and will require and verify any contractors or parties it hires to have adequate insurance coverage. Client agrees that its failure to comply with this clause invalidates any indemnity by OWC hereunder.
3. Pricing and Payment. The hourly rates charged for OWC's Services are adjusted annually in January of each year to reflect changes in the various elements that comprise such hourly rates. OWC reserves the right to periodically adjust its fee schedule. Except as otherwise provided in the first page of this agreement or Proposal, Client shall pay invoices upon receipt. Invoices not paid within thirty (30) days of invoice date incur a fee of 1½ % per month from the date of invoice and suspension by OWC of all Services.
4. Prevailing Wages. It is Client's legal responsibility to determine whether the Project is covered under prevailing wage regulations. Unless Client specifically informs Consultant in writing that the Project is a prevailing wage project and is identified as such in Consultant's Scope of Services, Client agrees to defend, indemnify and hold harmless Consultant from and against all liabilities, losses, claims, costs and damages (including reasonable costs and attorneys fees), resulting from a determination that the Project was covered under prevailing wage regulations.
5. Termination. Either party may terminate this Agreement at any time upon written notice, whether for cause or for convenience, in which event Client shall pay OWC for such portion of the Services performed and materials provided up to the date of termination.
6. Performance. OWC will perform the Services as an independent contractor and will not act as Client's agent or employee. The parties do not intend to create, and nothing in this Agreement will be construed to create, any special relationship or fiduciary duty. OWC will be subject to and operate in compliance with all federal, state and local laws and regulations. Client agrees that OWC will not be responsible for the means, methods, techniques, sequences or procedures of construction, for constant or exhaustive inspection of construction work, or for the safety procedures employed by any party other than its own employees and subcontractors. OWC will only sign certifications relating to the Services if OWC agreed in writing prior to the commencement of the Services to provide them. Such certifications are statements of professional opinion only. OWC will not be liable for delay or failure to perform its Services caused directly or indirectly by circumstances beyond its control, including but not limited to, acts of God, fire, flood, war, sabotage, accident, labor dispute, shortage, government action or inaction, changed conditions, site inaccessibility, or delays due to actions or inactions of Client or others.
7. Client Responsibilities. Client agrees to provide all available material, data, and information pertaining to the Services, including, without limitation, (i) composition, quantity, toxicity, or potentially hazardous properties of any material known or believed to be present at any site, (ii) hazards that may be present, (iii) nature and location of underground or otherwise not readily apparent utilities, (iv) summaries and assessments of site past and present compliance status, (v) status of any judicial or administrative action concerning the site or Project, and (vi) Client's relevant benchmarks, plans, maps, and property ownership records. Client will ensure the cooperation of Client's employees, contractors and consultants ("Client Parties") with OWC. OWC is entitled to rely upon the accuracy and completeness of all information given by Client Parties.
8. Indemnity; Limitation of Liability. Client will defend, indemnify and hold harmless OWC, its managers and employees, from and against any all claims, demands, causes of action, damages or other liabilities, including but not limited to attorney's fees and other legal expenses reasonably incurred by OWC (collectively, "Claims"), that arise from performance of the Services or from OWC's acts, errors or omissions in connection with the Project or this Agreement, excepting Claims arising from the sole negligence or willful misconduct of OWC. The maximum aggregate liability of OWC in connection with this Agreement and all amendments thereto, whether based in contract or tort or otherwise in law or equity, will be limited to the greater of the compensation actually paid to OWC for the Services hereunder or \$50,000, and Client hereby releases OWC from any liability above such amount. As used in this clause 8, "OWC" includes OWC, its subcontractors, and each of their respective partners, officers, directors, shareholders and employees. Neither party will be liable to the other for any special, incidental, indirect, exemplary, punitive or consequential damages however arising incurred by either OWC or Client or for which either may be liable to a third party.
9. Reliance. The documents provided by OWC to Client under this Agreement may be based on information obtained from sources outside OWC's control. Other than the application of prudent professional care in their evaluation, OWC does not warrant, expressed or implied the accuracy thereof. All documentation furnished to Client is intended for the benefit of the Client for the purpose stated herein and is not intended or represented to be suited for reuse by Client or others. Any reuse or provision of the documents to others without the specific written consent of OWC for the specific purposes intended will be at user's sole risk and without liability and legal exposure to OWC.
10. Hazardous Materials: Samples. OWC will not take title to or be liable for any hazardous materials found at any project site. Any risk of loss with respect to all materials remains with the Client or the site owner, who will be considered the generator of such materials, execute all manifests as the generator of them, and be liable for the arrangement, transportation, treatment, and disposal of all material. All samples remain the Client's property. Client agrees to promptly, at its cost, remove and lawfully dispose of samples, cuttings, and hazardous materials.
11. Amendments, Changes, Assignment, Waiver, Compliance. This Agreement represents the entire agreement of the parties and may be modified only in a writing signed by both parties. To the extent of any inconsistency between this Agreement and any other document, the provisions of this Agreement will always prevail. Any preprinted terms and conditions on forms used by either party in the administration of this Agreement are void and shall not act to supplement or replace these Terms and Conditions. Neither party may assign this Agreement without the other's prior written consent. Waiver of any term, condition or breach of this Agreement will not operate as a waiver of any other term, condition or breach. Client and OWC shall abide by 41 CFR 60-1.4(a), 60-300.5(a) and 60-741.5(a), which prohibit discrimination against qualified individuals based on their status as protected veterans or individuals with disabilities, and prohibit discrimination against all individuals based on race, color, religion, sex or national origin. Covered contractors and subcontractors shall take affirmative action to employ and advance individuals without regard to race, color, religion, sex, national origin, protected veteran status or disability.

EXHIBIT C

BUSINESS REGISTRATION AND SALES AND USE TAX REQUIREMENTS

A. Business Registration

P.L. 2004, c.57, as amended by P.L. 2009, C.315 (N.J.S.A. 52:32-44) requires VENDOR (also "CONTRACTOR") to provide PRINCETON with its business registration and that of any named subcontractors prior to the time this Agreement is awarded. In addition:

1. A Subcontractor named in the proposal made by CONTRACTOR shall provide a copy of its business registration to CONTRACTOR who shall provide it to PRINCETON as provided above. No Contract with a subcontractor shall be entered into by CONTRACTOR under this Agreement with PRINCETON unless the subcontractor first provides CONTRACTOR with proof of a valid business registration.
2. PRINCETON will retain the proof of business registration in an alphabetical file.
3. CONTRACTOR shall maintain and submit to PRINCETON a list of subcontractors and their addresses that may be updated from time to time during the course of the contract performance. A complete and accurate list shall be submitted before final payment is made for goods provided or services rendered under the Agreement.

B. Sales and Use Tax

1. For the term of this Agreement, CONTRACTOR and each of its affiliates shall collect and remit to the Director of the Division of Taxation in the Department of the Treasury the use tax due pursuant to the "Sales and Use Tax Act," P.L. 1966, c.30 (C.54:32B-1 et seq.) on all their sales of tangible personal property delivered into this State.
2. CONTRACTOR shall include within its subcontracts the requirement that, for the term of this Agreement, the subcontractor and each of its affiliates shall collect and remit to the Director of the Division of Taxation in the Department of the Treasury the use tax due pursuant to the "Sales and Use Tax Act," P.L. 1966, c.30 (C.54:32B-1 et seq.) on all their sales of tangible personal property delivered into this State.

Information on the law and its requirements is available by calling (609) 292-9292.

TERMS & CONDITIONSEXEMPTION

Princeton is exempted by statute from payment of all Federal, State, and Municipal excise, sales and other taxes.
FEDERAL I.D. 30-0746654

LEGAL REQUIREMENTS

The vendor agrees to comply with all statutes, rules and regulations and orders set forth by the State of New Jersey, Federal Government, and ordinances of Princeton.

STATE REQUIREMENT (BUSINESS REGISTRATION REQUIREMENT)

N.J.S.A. 52:32-44 imposes the following requirements on contractors and all subcontractors that knowingly provide goods or perform services for a contractor fulfilling this contract:

- 1) the contractor shall provide written notice to its subcontractors to submit proof of business registration to the contractor;
- 2) prior to receipt of final payment from a contracting agency, a contractor must submit to the contracting agency an accurate list of all subcontractors or attest that none was used;
- 3) during the term of this contract, the contractor and its affiliates shall collect and remit, and shall notify all subcontractors and their affiliates that they must collect and remit to the Director, New Jersey Division of Taxation, the use tax due pursuant to the Sales and Use Tax Act, (N.J.S.A. 54:32B-1 et seq.) on all sales of tangible personal property delivered into this State. A contractor, subcontractor or supplier who fails to provide proof of business registration or provides false business registration information shall be liable to a penalty of \$25.00 for each day of violation, not to exceed \$50,000 for each business registration not properly provided or maintained under a contract with a contracting agency. Information on the law and its requirements is available by calling (609)292-9292

AUTHORIZATION TO PROCEED

Princeton shall not be responsible for materials delivered or services performed delivered without authority of its written order and properly signed and executed by authorized Princeton official (s).

QUALITY & QUANTITY

All materials or services furnished on this order must be as specified, and subject to Princeton officials' inspection and approval within a reasonable time after delivery at destination. Materials other than specified will be returned at the order must not be substituted without the review and approval of authorized Princeton official(s). Materials rejected will be returned at the vendor's risk and expense. Quantities and unit prices specified must be adhered to. In case of a change, it first requires Princeton approval or it will be paid at the quoted price and quantity.

ASSIGNMENT

Neither party shall assign or transfer this order or any interest therein or monies payable thereunder without the written consent of the other party and any assignment made without such consent shall be null and void, except that Princeton may assign this order and its interest therein to any affiliated corporation or to any corporation succeeding to Princeton's business without consent of vendor.

MANDATORY EQUAL EMPLOYMENT OPPORTUNITY LANGUAGE

N.J.S.A. 10:5-31 et seq., N.J.A.C. 17:27

GOODS, PROFESSIONAL SERVICES AND GENERAL SERVICE CONTRACTS

During the performance of this contract the contractor agrees as follows:

The contractor or subcontractor, where applicable, will not discriminate against any employee or applicant for employment because of age, race, creed, color, national origin, ancestry, marital status, affectional or sexual orientation, gender identity or expression, disability, nationality or sex. Except with respect to affectional or sexual orientation and gender identity or expression, the contractor will take affirmative action to ensure that such applicants are recruited and employed, and that employees are treated during employment, without regard to their age, race, creed, color, national origin, ancestry, marital status, affectional or sexual orientation, gender identity or expression, disability, nationality or sex. Such action shall include, but not limited to the following: employment, upgrading, demotion, or transfer; recruitment or recruitment advertising; layoff or termination; rates of pay or other forms of compensation; and selection for training, including apprenticeship. The contractor agrees to post in conspicuous places, available to employees and applicants for employment, notices to be provided by the Public Agency Compliance Officer setting forth provisions of this nondiscrimination clause.

The contractor or subcontractor, where applicable will, in all solicitations or advertisements for employees placed by or on behalf of the contractor, state that all qualified applicants will receive consideration for employment without regard to age, race, creed, color, national origin, ancestry, marital status, affectional or sexual orientation, gender identity or expression, disability, nationality or sex.

The contractor or subcontractor, where applicable, will send to each labor union or representative or workers with which it has a collective bargaining agreement or other contract or understanding, a notice, to be provided by the agency contracting officer advising the labor union or workers' representative of the contractor's commitments under this act and shall post copies of the notice in conspicuous places available to employees and applicants for employment.

The contractor or subcontractor where applicable, agrees to comply with any regulations promulgated by the Treasurer pursuant to N.J.S.A. 10:5-31 et seq., as amended and supplemented from time to time and the Americans with Disabilities Act.

The contractor or subcontractor agrees to make good faith efforts to employ minority and women workers consistent with the applicable county employment goals established in accordance with N.J.A.C. 17:27-5.2 or a binding determination of the applicable county employment goals determined by the Division, pursuant to N.J.A.C. 17:27-5.2.

The contractor or subcontractor agrees to inform in writing its appropriate recruitment agencies including, but not limited to, employment agencies, placement bureaus, colleges, universities, labor unions, that it does not discriminate on the basis of age, creed, color, national origin, ancestry, marital status, affectional or sexual orientation, gender identity or expression, disability, nationality or sex, and that it will discontinue the use of any recruitment agency which engages in direct or indirect discriminatory practices.

The contractor or subcontractor agrees to revise any of its testing procedures, if necessary, to assure that all personal testing conforms with the principles of job-related testing, as established by the statutes and court decisions of the State of New Jersey and as established by applicable Federal law and applicable Federal court decisions.

In conforming with the applicable employment goals, the contractor or subcontractor agrees to review all procedures relating to transfer, upgrading, downgrading and layoff to ensure that all such actions are taken with out regard to age, creed, color, national origin, ancestry marital status, affectional or sexualorientation, gender identity or expression, disability, national or sex, consistent with the statutes and court decisions of the State of New Jersey, and applicable Federal law and applicable Federal court decisions.

The contractor shall submit to the public agency, after notification of award but prior to execution of a goods and services contract, one of the following three documents:

- Letter of Federal Affirmative Action Plan Approval
- Certificate of Employee Information Report
- Employee Information Report Form AA302

The contractor and its subcontractor shall furnish such reports or other documents to the Division of Contract Compliance & EEO as may be requested by the Division from time to time in order to carry out the purposes of these regulations, and public agencies shall furnish such information as may be requested by the Division of Contract Compliance & EEO for conducting a compliance investigation pursuant to Subchapter 10 of the Administrative Code at N.J.A.C.17:27.



Staff Report

File #: R-26-122

Agenda Date: 4/13/2026

Agenda #: 4.

Resolution of the Mayor and Council of Princeton Authorizing Site License Agreements with Crown Castle Fiber LLC for 288 Witherspoon Street, 1288 Stuart Road, and 1267 Great Road

WHEREAS, Crown Castle Fiber LLC (“Crown Castle”) is expanding its network to meet the demands of telecommunications services and has identified a location in the Municipality of Princeton (“Municipality”) on which it wishes to locate, place, attach, install, operate, control, and maintain its equipment in the public right-of-way on facilities owned by the Municipality or owned by third parties; and

WHEREAS, Crown Castle and the Municipality entered into a Rights-of-Way Agreement on September 14, 2023; and

WHEREAS, a copy of this Agreement is on file in the office of the Princeton Clerk; and

WHEREAS, the Municipality requires a Site License Agreement to install and attach Wireless Installations on, under, and above the public right-of-way owned or controlled by the Municipality that provides the specific location and type of wireless equipment that will be deployed thereon; and

WHEREAS, the locations are described as follows:

288 Witherspoon Street (PRC-063) - Located on the westerly side of Witherspoon Street opposite Henry Avenue, this installation will be mounted on an existing utility pole with an overall height of 33 feet. All equipment will be pole-mounted and power will be fed from existing overhead wires on the same pole.

1288 Stuart Road (PCT-006) - Located on the southwest corner of Great Road and Stuart Road, this installation will be mounted on a new utility pole with an overall height of 42 feet. All equipment will be pole-mounted and power will be fed from existing overhead wires on adjacent poles.

1267 Great Road (PCT-015) - Located on the southeast corner of Great Road and Cherry Valley Road, this installation will be mounted on a new utility pole with an overall height of 46.5 feet. All equipment will be pole-mounted and power will be fed from existing overhead wires on adjacent poles.

WHEREAS, the Municipality wishes to enter into an agreement with Crown Castle that grants Crown Castle the right to install and attach Wireless Installations on, under and above the public right-of-way on, in and adjacent to the specific Structure and Infrastructure as identified in the Site License Agreements.

NOW, THEREFORE, BE IT RESOLVED by the Mayor and Council of Princeton on this 13th day of April 2026 as follows:

1. The preamble to this resolution is hereby incorporated as if fully restated herein.
2. The Mayor and Clerk are hereby authorized and directed to sign the Site License Agreement, a copy of

which is on file in the office of the Municipal Clerk, or such substantially similar agreement as may be approved by the Municipal Attorney and Municipal Engineer.

3. This resolution shall take effect immediately.



MUNICIPALITY OF PRINCETON

Department of Infrastructure
& Operations

400 Witherspoon Street

Princeton, NJ 08540

(609) 921-7077

engineering@princetonnj.gov

MEMORANDUM

To: Mayor and Council
From: James J. Purcell, PE, *Acting Land Use Engineer*
Subject: Crown Castle Site License Agreements – PRC-063, PCT-006, PCT-015
Date: April 13, 2026

Attached for your review and consideration are site license agreements with Crown Castle Fiber LLC and a resolution authorizing the Mayor and Clerk to sign the agreements. Crown Castle works with providers of cellular telecommunications to locate and collocate cell antenna nodes to expand their networks. These site license agreements will provide both 5G and enhanced 4G cell service to the community to meet the increasing demands on the telecommunications network.

The applications for these locations were reviewed and approved through the administrative review process stipulated in the Crown Castle Rights-of-Way Agreement approved by Council on September 11, 2023.

The agreements grant Crown Castle the right to install and attach wireless cellular installations on, under and above the public right-of-way on, in and adjacent to the specific Structure and Infrastructure identified in the attachments to each site license. These particular agreements pertain to the following installations within the existing rights-of-way:

1. 288 Witherspoon Street (PRC-063) – Located on the westerly side of Witherspoon Street opposite Henry Avenue, this installation will be mounted on an existing utility pole with an overall height of 33 feet. All equipment will be pole-mounted and power will be fed from existing overhead wires on the same pole. This facility will host T-Mobile.
2. 1288 Stuart Road (PCT-006) – Located on the southwest corner of Great Road and Stuart Road, this installation will be mounted on a new utility pole with an overall height of 42 feet. All equipment will be pole-mounted and power will be fed from existing overhead wires on adjacent poles. This facility will host T-Mobile and Verizon.
3. 1267 Great Road (PCT-015) – Located on the southeast corner of Great Road and Cherry Valley Road, this installation will be mounted on a new utility pole with an overall height of 46.5 feet. All equipment will be pole-mounted and power will be fed from existing overhead wires on adjacent poles. This facility will host T-Mobile and Verizon.

Please feel free to contact me with any questions at (609) 921-7077 ext. 7631 or by email at jpurcell@princetonnj.gov.

cc: Bernard Hvozdovic, Administrator
Dawn M. Mount, Clerk
Deanna Stockton, P.E., C.M.E., Municipal Engineer

SITE LICENSE AGREEMENT
288 Witherspoon Street

This Site License Agreement is made this _____ day of _____, 2026 by and between the MUNICIPALITY OF PRINCETON (“Licensor”) and CROWN CASTLE Fiber LLC, a Delaware Limited Liability Company (“Licensee”).

1. Rights of Way Use Agreement. As referenced in Exhibit 2 of a certain Rights of Way Use Agreement between Licensor and Licensee ("Agreement"), Licensee has submitted a Site License Application pursuant to the Agreement, and Licensor has reviewed the application and grants approval subject to the terms of this Site License Agreement. All of the terms and conditions of the Agreement are incorporated hereby by reference and made a part hereof without the necessity of repeating or attaching the Agreement. In the event of a contradiction or inconsistency between the terms of the Agreement and this Site License Agreement, the terms of this Site License Agreement shall govern. Capitalized terms used in this Site License Agreement shall have the same meaning ascribed to them in the Agreement unless otherwise indicated herein.
2. Project Description and Locations. Licensee shall have the right to install and attach Wireless Installations on, under, and above the public right of way owned or controlled by Licensor, on, in and adjacent to the specific Structure and Infrastructure as identified and described in Exhibit 1 attached hereto (collectively the "Licensed Site").
3. Term. The Site License Term of this Site License Agreement shall be as set forth in Section 2 of the Agreement.
4. Fee. The Fee shall be in the amount and otherwise payable in accordance with the Agreement as set forth in Section 4 of the Agreement.
5. Special Provisions, If Any (Specific to the Licensed Site).

[SIGNATURES APPEAR ON FOLLOWING PAGE]

LICENSOR:

MUNICIPALITY OF PRINCETON

By: _____

Print Name:

Title:

Date: _____

LICENSEE:

Crown Castle Fiber LLC
a New York Limited Liability Company

By: _____

Print Name:

Title:

Date: _____

EXHIBITS: Licensed Site, Wireless Installation Equipment List and Plans

EXHIBIT 1 TO SITE LICENSE AGREEMENT

Licensed Site, Wireless Installation Equipment List and Plans

Licensee Wireless Installation Reference: **PRC-063**

SCU: **528020**

Site Name: **288 Witherspoon Street**

FA / USID:

PTN / PACE:

Structure pole number: **SO-PT-POLE-61986**

Structure Latitude and Longitude (Approximate): **40.35757, -74.66323**

Wireless Installation Equipment List: Please see attached construction drawings referenced below:

Crown Castle Fiber LLC | 288 Witherspoon Street | Jurisdiction: Municipality of Princeton | Proposed Small Cell Site
dated 9/13/2023 last revised 8/12/2025

APPLICABLE BUILDING CODES AND STANDARDS

ALL WORK SHALL COMPLY WITH ALL APPLICABLE NATIONAL, STATE, AND LOCAL CODES AS ADOPTED BY THE LOCAL AUTHORITY HAVING JURISDICTION (AHJ) FOR THE LOCATION. THE EDITION OF THE AHJ ADOPTED CODES AND STANDARDS IN EFFECT ON THE DATE OF CONTRACT AWARD SHALL GOVERN THE DESIGN.

PSE&G SAFETY, ENGINEERING AND CONSTRUCTION DESIGN SPECIFICATION STANDARDS
PSE&G/CROWN JOINT POLE AGREEMENT (AS APPLICABLE)

ALL THIRD PARTY ATTACHMENTS ARE TO BE IN COMPLIANCE WITH THE LATEST VERSION OF PSE&G ENGINEERING AND CONSTRUCTION GUIDELINES FOR THIRD PARTY ANTENNA SYSTEMS MOUNTED ON PSE&G DISTRIBUTION WOOD POLES

ELECTRICAL CODE: NFPA 70-2020, NATIONAL ELECTRIC CODE

LIGHTNING PROTECTION CODE: NFPA 780 - 2006, LIGHTNING PROTECTION

IEEE C2 NATIONAL ELECTRIC SAFETY CODE (NESC) 2012

TIA-222-H-16, STRUCTURAL STANDARDS FOR STEEL ANTENNA TOWER AND ANTENNA SUPPORTING STRUCTURES, TIA 607 COMMERCIAL BUILDING GROUNDING AND BONDING REQUIREMENTS FOR TELECOMMUNICATIONS

TELCORDIA GR-63-CORE, NEBS REQUIREMENTS: PHYSICAL PROTECTION

TELCORDIA GR-78-CORE, GENERIC REQUIREMENTS FOR THE PHYSICAL DESIGN AND MANUFACTURE OF TELECOMMUNICATIONS EQUIPMENT

TELCORDIA GR-1275, GENERAL INSTALLATION REQUIREMENTS

ANSI T1.311, FOR TELECOM - DC POWER SYSTEMS - TELCOM, ENVIRONMENTAL PROTECTION

INSTITUTE FOR ELECTRICAL AND ELECTRONICS ENGINEERS (IEEE) 81, GUIDE FOR MEASURING EARTH RESISTIVITY, GROUND IMPEDANCE, AND EARTH SURFACE POTENTIALS OF A GROUND SYSTEM IEEE 1100 (1999) RECOMMENDED PRACTICE FOR POWERING AND GROUNDING ELECTRONIC EQUIPMENT

FOR ANY CONFLICTS BETWEEN SECTIONS OF LISTED CODES AND STANDARDS REGARDING MATERIAL, METHODS OF CONSTRUCTION OR OTHER REQUIREMENTS, THE MOST RESTRICTIVE REQUIREMENT SHALL GOVERN. WHERE THERE IS CONFLICT BETWEEN A GENERAL REQUIREMENT AND A SPECIFIC REQUIREMENT, THE SPECIFIC REQUIREMENT SHALL GOVERN.



Crown Castle Fiber LLC
288 Witherspoon St
Jurisdiction: Municipality of Princeton
Proposed Small Cell Node
Pole #: SO-PT-POLE-61986

INDEX TO SHEETS	
DWG #	DRAWING TITLE
1	COVER SHEET
2	GENERAL NOTES
3	EXISTING AND PROPOSED POLE CONFIGURATION
4	EXISTING POLE PHOTOS (N&S)
5	EXISTING POLE PHOTOS (E&W)
6	PROPOSED EQUIPMENT DETAILS
7	PROPOSED ANTENNA & RADIO DETAILS
8	WIRING DIAGRAM
9	DISCONNECT BOX

SCU #: 528020

PROJECT SUMMARY

CROWN CASTLE ID: PRC-063
 SCU #: 528020
 CARRIER ID: PH6025BA_31LAB
 LOCATION: 288 Witherspoon St, Municipality of Princeton, MERCER
 SITE COORDINATES: 40.35757000 N, -74.66323000 W
 POLE TYPE/CLASS: UTILITY POLE/CLASS 4 (EXISTING)
 POLE NUMBER: SO-PT-POLE-61986
 POWER COMPANY: PSE&G
 APPLICANT: CROWN CASTLE, 111 MARKET PLACE, SUITE 103, BALTIMORE, MD 21202
 CROWN CASTLE CONTACT: DAN POLISKY, (267) 400-6223
 ENGINEER: FRENCH & PARRELO ASSOCIATES, 2 RIVERSIDE DRIVE, SUITE 503, CAMDEN, NJ 08101
 CONTACT: ANTHONY CRISTIANO, (732) 312-9824

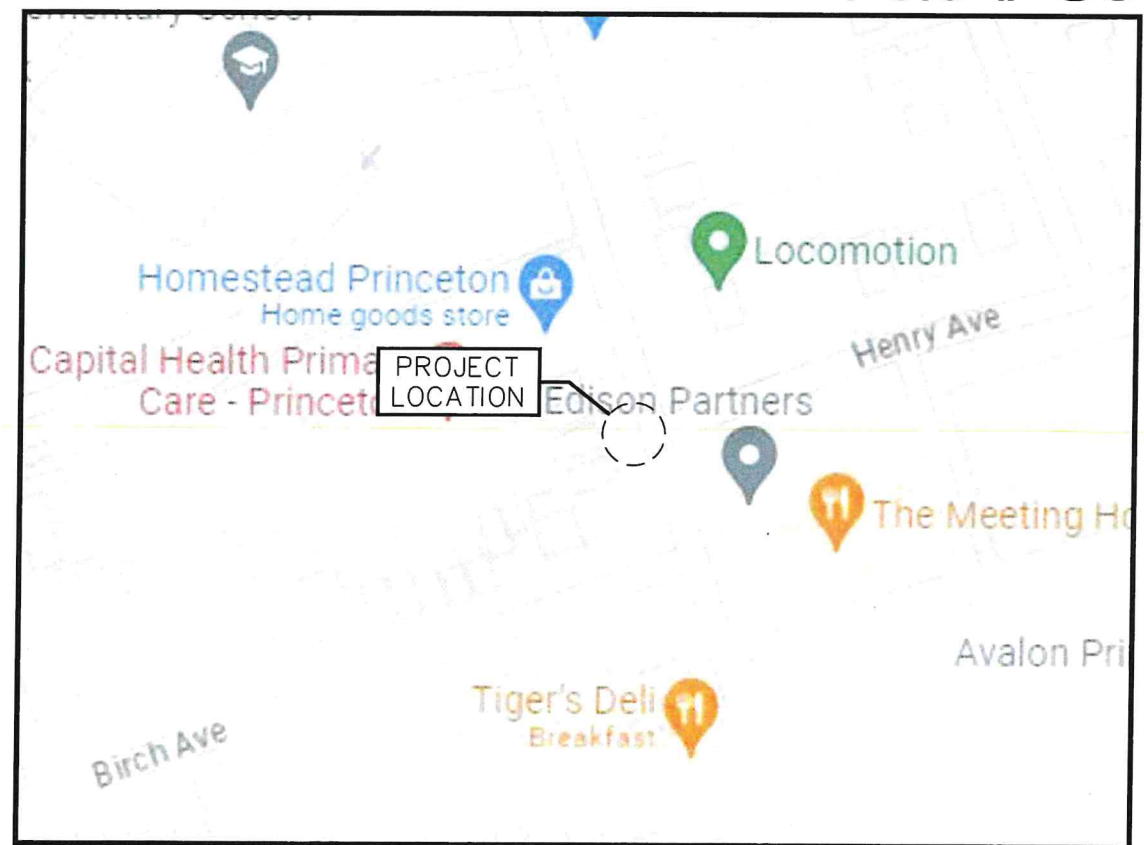

LOCATION MAP

Latitude: 40.35757000°N
 Longitude: -74.66323000°W
 Block: 6902, Lot: 8



NODE PLACEMENT

288 Witherspoon St
 Existing PSE&G wood pole
 on the west SIDE of Witherspoon St
 between Henry Ave & Birch St
 Pole ID: SO-PT-POLE-61986



Know what's below.
Call before you dig.

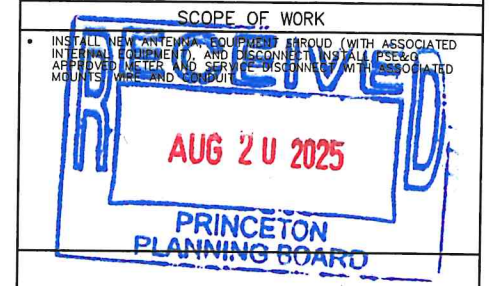

Peter J. Tardy 08/12/2025
 PETER J. TARDY, PE
 NEW JERSEY PROFESSIONAL ENGINEER LIC. NO. 41990



TITLE: Crown Castle Fiber LLC
 Pole #: SO-PT-POLE-61986
 288 WITHERSPOON STREET
 PRINCETON, NJ
 JURISDICTION: MUNICIPALITY OF PRINCETON

REVISIONS

REV.	DATE	REVISION DESCRIPTION
3	06/25/24	REVISED PER PSE&G COMMENTS
4	03/05/25	REVISED PER COMMENTS & EME REPORT
5	03/31/25	REVISED PER PSE&G COMMENTS
6	06/05/25	REVISED PER COMMENTS
7	08/12/25	REVISED PER COMMENTS

DRAWN BY:	CHECKED BY:	APPROVED BY:
D.R.	A.R.C.	P.J.T.

PROJECT NUMBER: 2438C.125.003

NODE ID: PRC-063

SCU # / CASCADE ID: 528020/PH6025BA_31LAB

DATE DRAWN: 09/13/2023

GENERAL NOTES:

- HANDICAP ACCESS REQUIREMENTS ARE NOT REQUIRED.
- FACILITY IS UNMANNED AND NOT FOR HUMAN HABITATION.
- FACILITY WILL BE REMOTELY MONITORED AND MAY BE VISITED APPROXIMATELY ONCE PER MONTH FOR STANDARD MAINTENANCE.
- FACILITY HAS NO PLUMBING OR REFRIGERANTS.
- THIS FACILITY SHALL MEET OR EXCEED ALL FAA AND FCC REGULATORY REQUIREMENTS.
- ALL PROPOSED MATERIAL SHALL BE FURNISHED AND INSTALLED BY CONTRACTOR UNLESS NOTED OTHERWISE. CABINETS, ANTENNAS/RRU AND CABLES FURNISHED BY OWNER AND INSTALLED BY CONTRACTOR.

GENERAL NOTES

PROJECT INFORMATION

THE FOLLOWING NOTES ARE NOT SPECIFIC TO THIS PROJECT. ALL NOTES THAT APPLY TO THE WORK SHOWN IN THESE CONSTRUCTION DOCUMENTS SHALL BE UTILIZED BY THE CONTRACTOR.

PART 1 - GENERAL REQUIREMENTS

1.1 THE WORK SHALL COMPLY WITH APPLICABLE NATIONAL CODES AND STANDARDS, LATEST EDITION, AND PORTIONS THEREOF, INCLUDED BUT NOT LIMITED TO THE FOLLOWING:

- A. GR-63-CORE NEBS REQUIREMENTS: PHYSICAL PROTECTION
B. GR-78-CORE GENERIC REQUIREMENTS FOR THE PHYSICAL DESIGN AND MANUFACTURE OF TELECOMMUNICATIONS EQUIPMENT.
C. NATIONAL FIRE PROTECTION ASSOCIATION CODES AND STANDARDS (NFPA) INCLUDING NFPA 70 (NATIONAL ELECTRICAL CODE - "NEC").
D. NFPA 101 (LIFE SAFETY CODE).
E. AMERICAN SOCIETY FOR TESTING OF MATERIALS (ASTM).
F. INSTITUTE OF ELECTRONIC AND ELECTRICAL ENGINEERS (IEEE).
G. PSE&G SAFETY, ENGINEERING AND CONSTRUCTION DESIGN SPECIFICATION STANDARDS
H. PSE&G/VERIZON JOINT POLE AGREEMENT.

1.2 DEFINITIONS:

- A. WORK: THE SUM OF TASKS AND RESPONSIBILITIES IDENTIFIED IN THE CONTRACT DOCUMENTS.
B. COMPANY: APPLICANT
C. ENGINEER: SYNONYMOUS WITH ARCHITECT & ENGINEER AND "A&E". THE DESIGN PROFESSIONAL HAVING PROFESSIONAL RESPONSIBILITY FOR DESIGN OF THE PROJECT.
D. CONTRACTOR: CONSTRUCTION CONTRACTOR; CONSTRUCTION VENDOR; INDIVIDUAL OR ENTITY WHO AFTER EXECUTION OF A CONTRACT IS BOUND TO ACCOMPLISH THE WORK.
E. THIRD PARTY VENDOR OR AGENCY: A VENDOR OR AGENCY ENGAGED SEPARATELY BY THE COMPANY, A&E, OR CONTRACTOR TO PROVIDE MATERIALS OR TO ACCOMPLISH SPECIFIC TASKS RELATED TO BUT NOT INCLUDED IN THE WORK.

1.3 POINT OF CONTACT: COMMUNICATION BETWEEN THE COMPANY AND THE CONTRACTOR SHALL FLOW THROUGH THE SINGLE COMPANY SITE DEVELOPMENT SPECIALIST OR OTHER PROJECT COORDINATOR APPOINTED TO MANAGE THE PROJECT FOR THE COMPANY.

1.4 ON-SITE SUPERVISION: THE CONTRACTOR SHALL SUPERVISE AND DIRECT THE WORK AND SHALL BE RESPONSIBLE FOR CONSTRUCTION MEASUREMENTS, METHODS, TECHNIQUES, SEQUENCES, AND PROCEDURES IN ACCORDANCE WITH THE CONTRACT DOCUMENTS. THE CONTRACTOR SHALL EMPLOY A COMPETENT SUPERINTENDENT WHO SHALL BE IN ATTENDANCE AT THE SITE AT ALL TIMES DURING PERFORMANCE OF THE WORK.

1.5 DRAWINGS, SPECIFICATIONS AND DETAILS REQUIRED AT JOBSITE: THE CONSTRUCTION CONTRACTOR SHALL MAINTAIN A FULL SET OF THE CONSTRUCTION DRAWINGS, STANDARD CONSTRUCTION DETAILS FOR WIRELESS SITES, AND THE STANDARD CONSTRUCTION SPECIFICATIONS FOR WIRELESS SITES AT THE JOBSITE FROM MOBILIZATIONS THROUGH CONSTRUCTION COMPLETION.

A. THE JOBSITE DRAWINGS, SPECIFICATIONS AND DETAILS SHALL BE CLEARLY MARKED DAILY IN PENCIL WITH ANY CHANGES IN CONSTRUCTION OVER WHAT IS DEPICTED IN THE DOCUMENTS. AT CONSTRUCTION COMPLETION, THE JOBSITE MARKUP SET SHALL BE DELIVERED TO THE COMPANY OR COMPANY'S DESIGNATED REPRESENTATIVE TO BE FORWARDED TO THE COMPANY'S A&E VENDOR FOR PRODUCTION OF "AS-BUILT" DRAWINGS.

1.6 USE OF JOB SITE: THE CONTRACTOR SHALL CONFINE ALL CONSTRUCTION AND RELATED OPERATIONS INCLUDING STAGING AND STORAGE OF MATERIALS AND EQUIPMENT, PARKING, TEMPORARY FACILITIES, AND WASTE STORAGE TO THE LEASE PARCEL UNLESS OTHERWISE PERMITTED BY THE CONTRACT DOCUMENTS.

1.7 NOTICE TO PROCEED:

- A. NO WORK SHALL COMMENCE PRIOR TO COMPANY'S WRITTEN NOTICE TO PROCEED.
B. UPON RECEIVING NOTICE TO PROCEED, CONTRACTOR SHALL FULLY PERFORM ALL WORK NECESSARY TO PROVIDE COMPANY. WITH AN OPERATIONAL WIRELESS FACILITY.

PART 2 - EXECUTION

2.1 TEMPORARY UTILITIES AND FACILITIES: THE CONTRACTOR SHALL BE RESPONSIBLE FOR ALL TEMPORARY UTILITIES AND FACILITIES NECESSARY EXCEPT AS OTHERWISE INDICATED IN THE CONSTRUCTION DOCUMENTS. TEMPORARY UTILITIES AND FACILITIES INCLUDE POTABLE WATER, HEAT, HVAC, ELECTRICITY, SANITARY FACILITIES, WASTE DISPOSAL FACILITIES, AND TELEPHONE/COMMUNICATION SERVICES. PROVIDE TEMPORARY UTILITIES AND FACILITIES IN ACCORDANCE WITH OSHA AND THE AUTHORITY HAVING JURISDICTION. CONTRACTOR MAY UTILIZE THE COMPANY ELECTRICAL SERVICE IN THE COMPLETION OF THE WORK WHEN IT BECOMES AVAILABLE. USE OF THE LESSORS OR SITE OWNER'S UTILITIES OR FACILITIES IS EXPRESSLY FORBIDDEN EXCEPT AS OTHERWISE ALLOWED IN THE CONTRACT DOCUMENTS.

2.2 ACCESS TO WORK: THE CONTRACTOR SHALL PROVIDE ACCESS TO THE JOB SITE FOR AUTHORIZED COMPANY PERSONNEL AND AUTHORIZED REPRESENTATIVES OF THE ARCHITECT/ENGINEER DURING ALL PHASES OF THE WORK.

2.3 TESTING: REQUIREMENTS FOR TESTING BY THIS CONTRACTOR SHALL BE AS INDICATED HEREWITH, ON THE CONSTRUCTION DRAWINGS, AND IN THE INDIVIDUAL SECTIONS OF THESE SPECIFICATIONS. SHOULD COMPANY CHOOSE TO ENGAGE ANY THIRD-PARTY TO CONDUCT ADDITIONAL TESTING, THE CONTRACTOR SHALL COOPERATE WITH AND PROVIDE A WORK AREA FOR COMPANY'S TEST AGENCY.

2.4 COMPANY FURNISHED MATERIAL AND EQUIPMENT: ALL HANDLING, STORAGE AND INSTALLATION OF COMPANY FURNISHED MATERIAL AND EQUIPMENT SHALL BE IN ACCORDANCE WITH THE REQUIREMENTS OF THE CONTRACT DOCUMENTS AND WITH THE MANUFACTURER'S INSTRUCTIONS AND RECOMMENDATIONS.

A. CONTRACTOR SHALL PROCURE ALL OTHER REQUIRED WORK RELATED MATERIALS NOT PROVIDED BY COMPANY TO SUCCESSFULLY CONSTRUCT A WIRELESS FACILITY.

2.5 DIMENSIONS: VERIFY DIMENSIONS INDICATED ON DRAWINGS WITH FIELD DIMENSIONS BEFORE FABRICATION OR ORDERING OF MATERIALS. DO NOT SCALE DRAWINGS.

2.6 EXISTING CONDITIONS: NOTIFY THE COMPANY REPRESENTATIVE OF EXISTING CONDITIONS DIFFERING FROM THOSE INDICATED ON THE DRAWINGS. DO NOT REMOVE OR ALTER STRUCTURAL COMPONENTS WITHOUT PRIOR WRITTEN APPROVAL FROM THE ARCHITECT AND ENGINEER.

2.7 CONTRACTOR SHALL CONTACT ONE CALL A MINIMUM OF 72 HOURS PRIOR TO THE START OF CONSTRUCTION WHEN COMPLETING ANY UNDERGROUND UTILITY WORK.

PART 3 - RECEIPT OF MATERIAL & EQUIPMENT

3.1 RECEIPT OF MATERIAL AND EQUIPMENT: CONTRACTOR IS RESPONSIBLE FOR COMPANY PROVIDED MATERIAL AND EQUIPMENT AND UPON RECEIPT SHALL:

- A. ACCEPT DELIVERIES AS SHIPPED AND TAKE RECEIPT.
B. VERIFY COMPLETENESS AND CONDITION OF ALL DELIVERIES.
C. TAKE RESPONSIBILITY FOR EQUIPMENT AND PROVIDE INSURANCE PROTECTION AS REQUIRED IN AGREEMENT.
D. RECORD ANY DEFECTS OR DAMAGES WITHIN TWENTY-FOUR HOURS AFTER RECEIPT AND REPORT TO COMPANY OR ITS DESIGNATED PROJECT REPRESENTATIVE OF SUCH.
E. PROVIDE SECURE AND NECESSARY WEATHER PROTECTED WAREHOUSING.
F. COORDINATE SAFE AND SECURE TRANSPORTATION OF MATERIAL AND EQUIPMENT, DELIVERING AND OFF-LOADING FROM CONTRACTOR'S WAREHOUSE TO SITE.

PART 4 - GENERAL REQUIREMENTS FOR CONSTRUCTION

4.1 CONTRACTOR SHALL KEEP THE SITE FREE FROM ACCUMULATING WASTE MATERIAL, DEBRIS, AND TRASH. AT THE COMPLETION OF THE WORK, CONTRACTOR SHALL REMOVE FROM THE SITE ALL REMAINING RUBBISH, IMPLEMENTS, TEMPORARY FACILITIES, AND SURPLUS MATERIALS.

4.2 EQUIPMENT AREA SHALL AT ALL TIMES BE MAINTAINED "BROOM CLEAN" AND CLEAR OF DEBRIS.

4.3 CONTRACTOR SHALL TAKE ALL REASONABLE PRECAUTIONS TO DISCOVER AND LOCATE ANY HAZARDOUS CONDITION.

- A. IN THE EVENT CONTRACTOR ENCOUNTERS ANY HAZARDOUS CONDITION WHICH HAS NOT BEEN ABATED OR OTHERWISE MITIGATED, CONTRACTOR AND ALL OTHER PERSONS SHALL IMMEDIATELY STOP WORK IN THE AFFECTED AREA AND NOTIFY COMPANY IN WRITING. THE WORK IN THE AFFECTED AREA SHALL NOT BE RESUMED EXCEPT BY WRITTEN NOTIFICATION BY COMPANY.
B. CONTRACTOR AGREES TO USE CARE WHILE ON THE SITE AND SHALL NOT TAKE ANY ACTION THAT WILL OR MAY RESULT IN OR CAUSE THE HAZARDOUS CONDITION TO BE FURTHER RELEASED IN THE ENVIRONMENT, OR TO FURTHER EXPOSE INDIVIDUALS TO THE HAZARD.

4.4 CONTRACTOR'S ACTIVITIES SHALL BE RESTRICTED TO THE PROJECT LIMITS. SHOULD AREA OUTSIDE THE PROJECT LIMITS BE AFFECTED BY CONTRACTOR'S ACTIVITIES, CONTRACTOR SHALL IMMEDIATELY RETURN THEM TO ORIGINAL CONDITION.

4.5 CONDUCT TESTING AS REQUIRED HEREIN.

4.6 INSTALLATION, MAINTENANCE, AND REPAIR UNDER ENERGIZED CONDITIONS SHALL BE CONDUCTED USING APPROPRIATE INSULATED EQUIPMENT SUCH AS RUBBER GLOVES, SLEEVES, AND TEMPORARY RUBBER CONDUCTOR INSULATION TO LIMIT SERVICE INTERRUPTIONS.

4.7 ALL HARDWARE USED TO SUPPORT THE EQUIPMENT SHALL BE GALVANIZED IN NEW CONDITION, MADE BY A REPUTABLE MANUFACTURER, DESIGNED SPECIFICALLY FOR THE INTENDED USE AND CAPABLE OF WITHSTANDING ALL DESIGNED LOADS.

PART 5 - TEST AND INSPECTIONS

5.1 TESTS AND INSPECTIONS:

- A. THE CONTRACTOR SHALL BE RESPONSIBLE FOR ALL CONSTRUCTION TESTS, INSPECTIONS AND PROJECT DOCUMENTATION.
B. CONTRACTOR SHALL COORDINATE TEST AND INSPECTION SCHEDULES WITH COMPANY'S REPRESENTATIVE WHO MUST BE ON SITE TO WITNESS SUCH TESTS AND INSPECTIONS.
C. THE THIRD PARTY TESTING AGENCY IS TO BE FAMILIAR WITH THE APPLICABLE REQUIREMENTS FOR THE TESTS TO BE DONE, EQUIPMENT TO BE USED, AND ASSOCIATED HEALTH AND SAFETY ISSUES.
D. SITE RESISTANCE TO EARTH TESTING PER EXHIBIT: CELL SITE GROUNDING SYSTEM DESIGN.
E. ANTENNA AND COAX SWEEP TESTS PER EXHIBIT: ANTENNA TRANSMISSION LINE ACCEPTANCE STANDARDS.
F. ALL OTHER TESTS REQUIRED BY COMPANY OR JURISDICTION.

PART 6 - TRENCHING AND BACKFILLING

6.1 TRENCHING AND BACKFILLING:

- A. THE CONTRACTOR SHALL PERFORM ALL EXCAVATION OF EVERY DESCRIPTION AND OF WHATEVER SUBSTANCES ENCOUNTERED, TO THE DEPTHS INDICATED ON THE CONSTRUCTION DRAWINGS OR AS OTHERWISE SPECIFIED.
B. PROTECTION OF EXISTING UTILITIES: THE CONTRACTOR SHALL CHECK WITH THE LOCAL UTILITIES AND THE RESPECTIVE UTILITY LOCATOR COMPANIES PRIOR TO STARTING EXCAVATION OPERATIONS IN EACH RESPECTIVE AREA TO ASCERTAIN THE LOCATIONS OF KNOWN UTILITY LINES. THE LOCATIONS, NUMBER AND TYPES OF EXISTING UTILITY LINES DETAILED ON THE CONSTRUCTION DRAWINGS ARE APPROXIMATE AND DO NOT REPRESENT EXACT INFORMATION. THE CONTRACTOR SHALL BE RESPONSIBLE FOR REPAIRING ALL LINES DAMAGED DURING EXCAVATION AND ALL ASSOCIATED OPERATIONS. ALL UTILITY LINES UNCOVERED DURING THE EXCAVATION OPERATIONS SHALL BE PROTECTED FROM DAMAGE DURING EXCAVATION AND ASSOCIATED OPERATIONS. ALL REPAIRS SHALL BE APPROVED BY THE UTILITY COMPANY.
C. HAND DIGGING: UNLESS APPROVED IN WRITING OTHERWISE, ALL DIGGING IS TO BE DONE BY HAND.
D. DURING EXCAVATION, MATERIAL SUITABLE FOR BACKFILLING SHALL BE STOCKPILED IN AN ORDERLY MANNER A SUFFICIENT DISTANCE FROM THE BANKS OF THE TRENCH TO AVOID OVERLOADING AND TO PREVENT SLIDES OR CAVE-INS. ALL EXCAVATED MATERIALS NOT REQUIRED OR SUITABLE FOR BACKFILL SHALL BE REMOVED AND DISPOSED OF AT THE CONTRACTOR'S EXPENSE.
E. GRADING SHALL BE DONE AS MAY BE NECESSARY TO PREVENT SURFACE WATER FROM FLOWING INTO TRENCHES OR OTHER EXCAVATIONS, AND ANY WATER ACCUMULATING THEREIN SHALL BE REMOVED BY PUMPING OR BY OTHER APPROVED METHOD.
F. SHEETING AND SHORING SHALL BE DONE AS NECESSARY FOR THE PROTECTION OF THE WORK AND FOR THE SAFETY OF PERSONNEL. UNLESS OTHERWISE INDICATED, EXCAVATION SHALL BE BY OPEN CUT, EXCEPT THAT SHORT SECTIONS OF A TRENCH MAY BE TUNNELED IF THE CONDUIT CAN BE SAFELY AND PROPERLY INSTALLED AND BACKFILL CAN BE PROPERLY TAMPED IN SUCH TUNNEL SECTIONS. EARTH EXCAVATION SHALL COMPRISE ALL MATERIALS AND SHALL INCLUDE CLAY, SILT, SAND, MUCK, GRAVEL, HARDPAN, LOOSE SHALE, AND LOOSE STONE.
G. TRENCHES SHALL BE OF NECESSARY WIDTH FOR THE PROPER LAYING OF THE CONDUIT OR CABLE, AND THE BANKS SHALL BE AS NEARLY VERTICAL AS PRACTICABLE. THE BOTTOM OF THE TRENCHES SHALL BE ACCURATELY GRADED TO PROVIDE UNIFORM BEARING AND SUPPORT FOR EACH SECTION OF THE CONDUIT OR CABLE ON UNDISTURBED SOIL AT EVERY POINT ALONG ITS ENTIRE LENGTH. EXCEPT WHERE ROCK IS ENCOUNTERED, CARE SHALL BE TAKEN NOT TO EXCAVATE BELOW THE DEPTHS INDICATED. WHERE ROCK EXCAVATIONS ARE NECESSARY, THE ROCK SHALL BE EXCAVATED TO A MINIMUM OVER DEPTH OF 6 INCHES BELOW THE TRENCH DEPTHS INDICATED ON THE CONSTRUCTION DRAWINGS OR SPECIFIED. OVER DEPTHS IN THE ROCK EXCAVATION AND UNAUTHORIZED OVER DEPTHS SHALL BE THOROUGHLY BACK FILLED AND TAMPED TO THE APPROPRIATE GRADE. WHENEVER WET OR OTHERWISE UNSTABLE SOIL THAT IS INCAPABLE OF PROPERLY SUPPORTING THE CONDUIT OR CABLE IS ENCOUNTERED IN THE BOTTOM OF THE TRENCH, SUCH SOLID SHALL BE REMOVED TO A MINIMUM OVER DEPTH OF 6 INCHES AND THE TRENCH BACKFILLED TO THE PROPER GRADE WITH EARTH OF OTHER SUITABLE MATERIAL, AS HEREINAFTER SPECIFIED.
H. BACKFILLING OF TRENCHES: TRENCHES SHALL NOT BE BACKFILLED UNTIL ALL SPECIFIED TESTS HAVE BEEN PERFORMED AND ACCEPTED. WHERE COMPACTED BACKFILL IS NOT INDICATED THE TRENCHES SHALL BE CAREFULLY BACKFILLED WITH SELECT MATERIAL SUCH AS EXCAVATED SOILS THAT ARE FREE OF ICE, SNOW, ROOTS, SOD, RUBBISH OR STONES, DEPOSITED IN 6 INCH LAYERS AND THOROUGHLY AND CAREFULLY RAMMED UNTIL THE CONDUIT OR CABLE HAS A COVER OF NOT LESS THAN 1 FOOT. THE REMAINDER OF THE BACKFILL MATERIAL SHALL BE GRANULAR IN NATURE AND SHALL NOT CONTAIN ICE, SNOW, ROOTS, SOD, RUBBISH, OR STONES OF 2-1/2 INCH MAXIMUM DIMENSION. BACKFILL SHALL BE CAREFULLY PLACED IN THE TRENCH AND IN 1 FOOT LAYERS AND EACH LAYER TAMPED. SETTling THE BACKFILL WITH WATER WILL BE PERMITTED. THE SURFACE SHALL BE GRADED TO A REASONABLE UNIFORMITY AND THE MOUNDING OVER THE TRENCHES LEFT IN A UNIFORM AND NEAT CONDITION.

THIS IS AN UNMANNED AND RESTRICTED ACCESS EQUIPMENT FACILITY AND WILL BE USED FOR THE TRANSMISSION OF RADIO SIGNALS FOR THE PURPOSE OF PROVIDING PUBLIC WIRELESS COMMUNICATIONS SERVICE.

NO POTABLE WATER SUPPLY IS TO BE PROVIDED AT THIS LOCATION.

NO WASTE WATER WILL BE GENERATED AT THIS LOCATION.

NO SOLID WASTE WILL BE GENERATED AT THIS LOCATION.

COMPANY MAINTENANCE CREW (TYPICALLY ONE PERSON) WILL MAKE AN AVERAGE OF ONE TRIP PER MONTH AT ONE HOUR PER VISIT.

PSE&G OPERATIONAL SAFETY PROCEDURES

- 1. INTERFERENCE WITH ANY PSE&G COMMUNICATION OR DISTRIBUTION AUTOMATION RADIO SYSTEM WILL NOT BE PERMITTED. THE RADIO SYSTEM IS THE PRIMARY COMMUNICATION FOR EMPLOYEES OF PSE&G AND IS ESSENTIAL FOR RESPONSE TO EMERGENCIES. THIS NON-INTERFERENCE CLAUSE SHALL APPLY EVEN IF THE PSE&G RADIO EQUIPPED VEHICLE OR HANDHELD UNIT IS TEMPORARILY LOCATED NEAR THE ANTENNA SYSTEM WHILE PERFORMING WORK.
2. THE LICENSEE IS RESPONSIBLE FOR PLACING A SIGN NEAR THE POWER SUPPLY INDICATING A 24-HOUR CONTACT TELEPHONE NUMBER AND SITE IDENTIFICATION IN CASE OF EMERGENCY. THE PHONE NUMBER MUST BE VISIBLE FROM THE GROUND AND THE SIGN MUST BE EASILY READABLE, ULTRAVIOLET (UV) RESISTANT MATERIAL.
3. SIGNAGE IS TO BE PLACED BY THE LICENSEE REGARDING RF EMISSIONS IN ACCORDANCE WITH THE LATEST IEEE & OSHA STANDARDS CONSISTENT WITH THE REQUIREMENTS OUTLINED IN THE RF STUDY INCLUDED WITH THIS SUBMITTAL. A SMALL CELL SITE IDENTIFIER SIGN IS TO BE INSTALLED IN PROXIMITY TO THE METER AND/OR DISCONNECT.
4. THE LICENSEE'S POWER SUPPLY MUST BE EQUIPPED WITH A MEANS OF DISCONNECT BETWEEN THE POWER SOURCE AND THE EQUIPMENT. THE LICENSEE'S MEANS OF DISCONNECT MUST CUTOFF AC POWER TO THE EQUIPMENT AND BACKUP BATTERY POWER (IF APPLICABLE). THE POWER SUPPLY WILL BE EQUIPPED WITH AN EXTERNAL INDICATOR LIGHT THAT WILL VERIFY THE LICENSEE'S EQUIPMENT HAS BEEN RENDERED INOPERABLE. ALL ASPECTS OF THE TOTAL INSTALLATION SHALL BE IN ADHERENCE TO THE CURRENT EDITIONS OF BOTH THE NESC AND THE NEC.

CONSTRUCTION NOTES

- 1. CONTRACTOR TO CALL ONE CALL 72 HOURS PRIOR TO EXCAVATING.
2. ALL LANDSCAPING TO BE RESTORED TO ORIGINAL CONDITION OR BETTER.

GROUNDING NOTES

- 1. GROUND TESTED AT 25 OHMS OR LESS. CONTRACTOR TO PROVIDE EVIDENCE OF CONFORMING GROUNDING SYSTEM TO ENGINEER.
2. GROUND RODS SHALL BE "COPPER WELD" STEEL, 5/8" DIA X 8' LONG.
3. GROUND CONDUCTOR TRUNK SHALL BE MEDIUM HARD DRAWN, SOLID, INSULATED NO. 4 AWG COPPER. INSULATION THICKNESS SHALL BE 60 MILS OF UNFILLED, BLACK, CROSS-LINKED POLYETHYLENE BEARING THE MANUFACTURER'S NAME AND YEAR OF MANUFACTURE IMPRINTED ON THE CONDUCTOR AT INTERVALS OF APPROXIMATELY ONE FOOT.
4. GROUND CONDUCTOR TRUNK SHALL BE CLEARLY IDENTIFIED WITH A BRASS TAG OR OTHER ACCEPTABLE MEANS, ATTACHED TO THE CONDUCTOR AT THE BASE OF THE POLE, INDICATING COMPANY'S IDENTIFICATION.
5. ALL CONNECTORS SHALL BE BRASS.
6. ALL METALLIC PARTS OF THE INSTALLATION ON THE POLE SHALL BE BONDED TOGETHER AND GROUNDED TO COMPANY'S GROUNDING SYSTEM.
7. CONTRACTOR SHALL LEAVE GROUND VISIBLE UNTIL ELECTRICAL INSPECTION COMPLETED, THEN DRIVE 6" BELOW GRADE

UTILITY POLE CONSTRUCTION NOTES

- 1. NO BOLT THREADS TO PROTRUDE MORE THAN 1-1/2".
2. FILL ALL HOLES LEFT IN POLE FROM REARRANGEMENT OF CUMBERS.
3. CABLE NOT TO IMPEDE 15" CLEAR SPACE OFF POLE FACE.
4. USE CABLE CLAMPS TO SECURE CABLE TO ARMS. PLACE 2" CABLE ID TAGS ON BOTH SIDES OF ARMS. ALL TAGS SHOULD BE SECURELY ATTACHED.
5. FILL VOID AROUND CABLES AT CONDUIT OPENING WITH FOAM SEALANT TO PREVENT WATER INTRUSION.
6. EQUIPMENT/ANTENNA SPACING NEAR POWER LINES AND COMMUNICATIONS CABLES TO BE INSTALLED PER POLE OWNER/UTILITY COMPANY SPECIFICATIONS.
7. CLEARANCE TO CONDUCTOR VALUES FOR EACH VOLTAGE CLASS SHALL BE IN ACCORDANCE WITH NESC 235C, H, I AND TABLE 235-6 U.N.O.
8. CONTRACTOR TO ROUTE FIBER AND POWER AERIALLY TO NEAREST UTILITY DEMARK UNLESS OTHERWISE SPECIFIED. FIELD VERIFY LOCATIONS PRIOR TO CONSTRUCTION.
9. MAINTAIN 12" SPACE BETWEEN PROPOSED AND EXISTING COMS.
10. ALL EQUIPMENT ATTACHED TO THE POLE SHALL BE THROUGH BOLTED.

PETER J. TARDY, PE
NEW JERSEY PROFESSIONAL ENGINEER
LIC. NO. 41990



TITLE: Crown Castle Fiber LLC
Pole #: SO-PT-POLE-61986
288 WITHERSPOON STREET
PRINCETON, NJ
JURISDICTION: MUNICIPALITY OF PRINCETON

Table with 2 columns: REV. DATE, REVISION DESCRIPTION. Contains 7 revision entries.

DRAWN BY: D.R. CHECKED BY: A.R.C. APPROVED BY: P.J.T.

PROJECT NUMBER: 2438C.125.003

NODE ID: PRC-063

SCU # / CASCADE ID: 528020/PH6025BA_31LAB

DATE DRAWN: 09/13/2023

SHEET: 2 of 9

- GENERAL NOTES:**
- ALL EQUIPMENT MOUNTING HARDWARE TO BE STAINLESS STEEL OR GALVANIZED.
 - OWNER AND CONTACT INFORMATION TO BE CLEARLY MARKED AND READABLE FROM GROUND LEVEL.
 - PROPER OSHA SIGN AND SYMBOL TO BE CLEARLY MARKED AND READABLE FROM GROUND LEVEL AND MAINTAINED BY OWNER.
 - SERVICE DISCONNECT TO BE CLEARLY MARKED.
 - THIRD PARTY ATTACHMENT CUSTOMER TO PROVIDE POLE LOADING ANALYSIS AS REQUIRED.
 - CONDUIT TO BE INSTALLED IN A MANNER TO PREVENT WATER ENTRY.
 - ELECTRICAL EQUIPMENT TO BE CONNECTED TO DRIVEN GROUND ROD IN COMPLIANCE WITH ALL APPLICABLE CODES.
 - FINAL CONFIGURATION PENDING POTENTIAL MAKE READY WORK TO BE PERFORMED BY POLE OWNER OR UTILITY OWNER.
 - VERTICAL CONDUIT ROUTING TO BE INSTALLED SO AS NOT TO INTERFERE WITH EXISTING OBSTRUCTIONS.
 - CONTRACTOR TO NOTIFY APPLICANT IF UTILITY POLE APPURTENANCES DIFFER FROM DRAWINGS AND/OR INTERFERE WITH PROPOSED INSTALLATIONS.

NOTE:
ALL NEW ANTENNA, EQUIPMENT SHROUD, METER, DISCONNECT, CONDUIT WIRING, AND ASSOCIATED MOUNTING EQUIPMENT AND HARDWARE SHALL BE BLACK WITH A MATT FINISH.

- PROPOSED ANTENNA:
(1) AMPHENOL 2C6U2VT360X06Fwys4
24.0"x14.6" (HxD) - 28.0 LBS
- INSTALL ANTENNA MOUNTING BRACKET
- INSTALL POLE TOP MOUNT
- EXISTING UTILITY POLE TO REMAIN
TOP HEIGHT = 29'-6" (AGL)
- INSTALL 2" PVC RISER U-GUARD:
PROPOSED #4 AWG GROUND WIRE AND COAX/FIBER CABLES TO BE ROUTED WITHIN
- INSTALL 1.25" PVC SCH. 80 POWER RISER CONDUIT FROM METER TO SECONDARY
- INSTALL SHROUD CABINET:
RAYCAP RAES-235418-C35
48.0"x24.0"x24.0" (HxWxD) - 433 LBS
INTERNAL ERICSSON COMPONENTS TO BE INSTALLED:
OAD-9-S, PSU AC DB, & FRONTHAUL 6585
EQUIPMENT COLOR: MATT BLACK
TO BE THRU-BOLTED TO POLE
- INSTALL RADIO UNIT WITHIN NEW SHROUD CABINET:
(1) ERICSSON RADIO 4455 B2/B25 B66A
31.3"x10.9"x5.9" (HxWxD) - 67.2 LBS
- INSTALL RADIO UNIT WITHIN NEW SHROUD CABINET:
(1) ERICSSON RADIO 8863 B41 W/FAN
18.1"x14.8"x5.7" (HxWxD) - 50.9 LBS
- INSTALL DIPLEXER WITHIN NEW SHROUD CABINET:
(1) KAELUS DBCT156F1V12-1
4.33"x9.41"x3.51" (HxWxD) - 9.7 LBS
- INSTALL 100A DISCONNECT:
(1) RAYCAP RSD-FMC-Z16MS-21NN
18.25"x9.10"x6.05" (HxWxD) - 23.6 LBS
EQUIPMENT COLOR: MATT BLACK
TO BE MOUNTED BELOW EQUIPMENT SHROUD
- INSTALL MULTIPLEXER WITHIN NEW SHROUD CABINET:
(1) ERICSSON OAD-9-S
1.1"x4.7"x4.6" (HxWxD) - 0.66 LBS
- INSTALL PSU WITHIN NEW SHROUD CABINET:
(1) ERICSSON PSU AC DB
2.72"x10.79"x7.09" (HxWxD) - 11.5 LBS
- INSTALL FRONTHAUL WITHIN NEW SHROUD CABINET:
(1) ERICSSON FRONTHAUL 6585
9.63"x5.12"x1.50" (HxWxD) - 1.54 LBS
- INSTALL "BLUE" NOTICE POLE WORKER SIGN AT LEAST 10' ABOVE GRADE PER EME REPORT
- INSTALL (2) "YELLOW" CAUTION SIGNS AT LEAST 6' BELOW THE ANTENNA ON EITHER SIDE OF THE POLE WITH A LISTED STANDOFF DISTANCE OF 14" NEAR THE ANTENNA PER EME REPORT

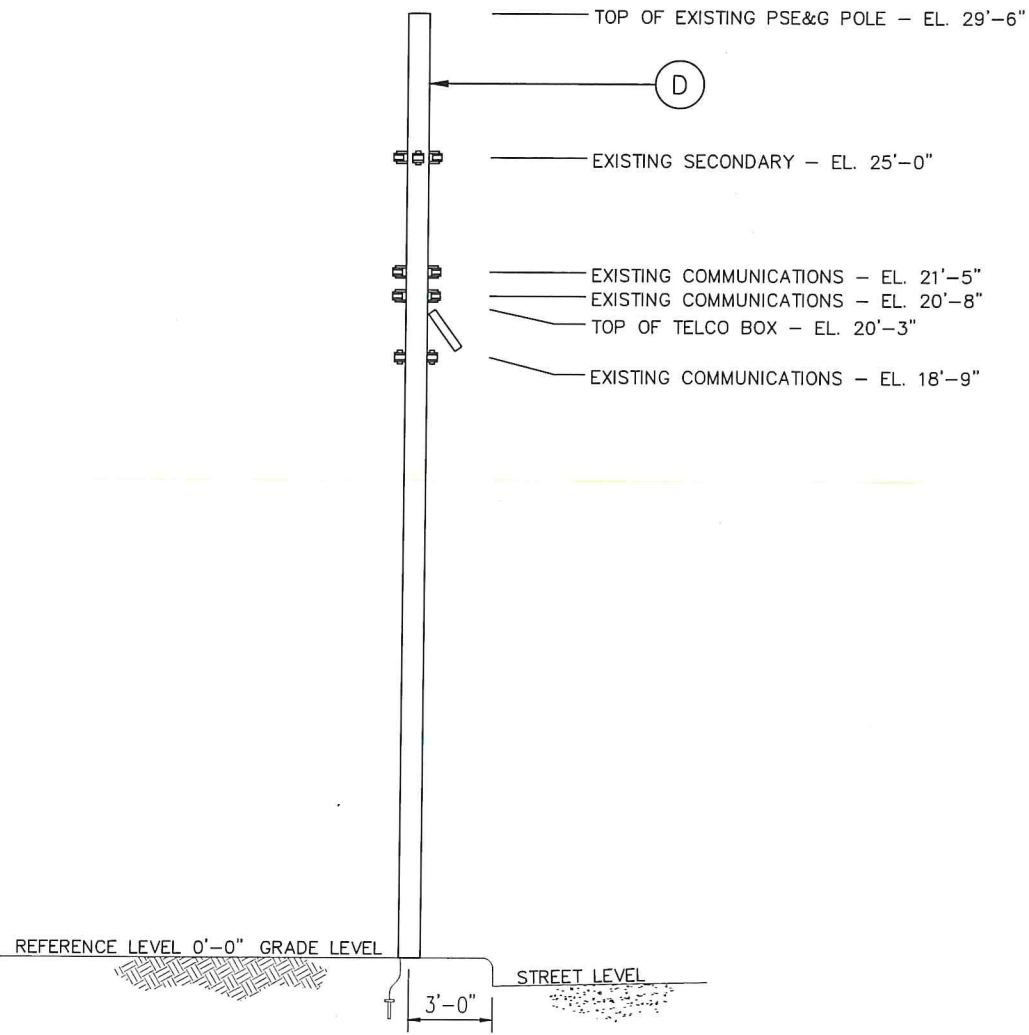

EXISTING POLE DETAIL
LOOKING NORTH

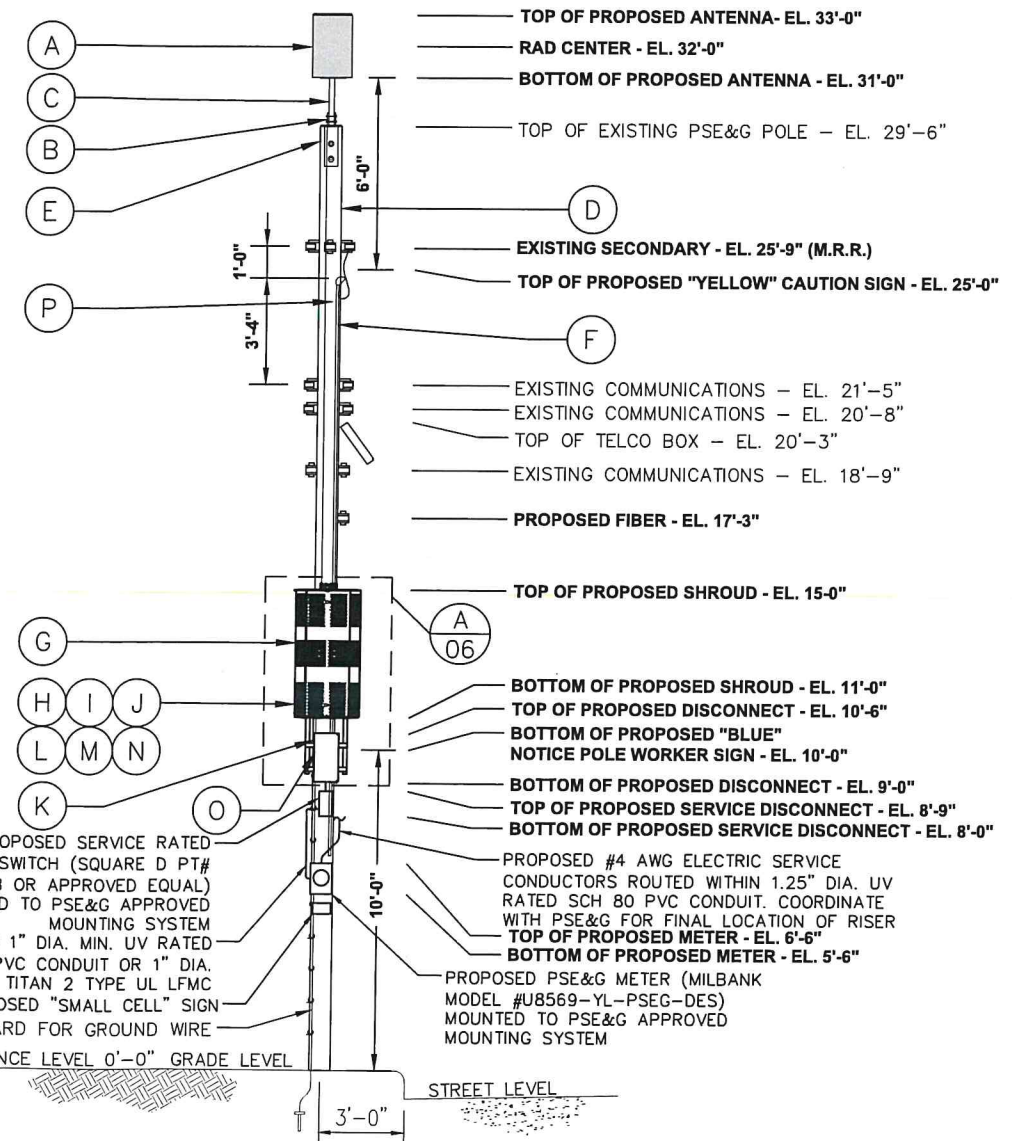
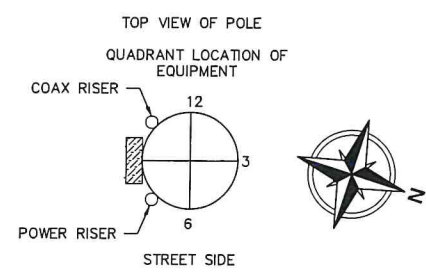

PROPOSED POLE DETAIL
LOOKING NORTH

- NOTES:**
- PROPOSED POWER CONNECTIONS TO BE COORDINATED WITH PSE&G.
 - METER TO BE POSITIONED IN A MANNER SUCH THAT THE TECHNICIAN FACES ONCOMING TRAFFIC.
 - ALL DISTURBED SIDEWALK FLAGS SHALL BE REPLACED IN THEIR ENTIRETY.
 - PREVIOUS/SHORTER WOOD POLE TO BE REMOVED, LEAVING ONLY ONE WOOD POLE AT THE PROPOSED SITE LOCATION.

Peter J. Tardy
PETER J. TARDY, PE
NEW JERSEY PROFESSIONAL ENGINEER
DATE: 08/12/2025
LIC. NO. 41990

FPA
FRENCH & PARRELLO
ASSOCIATES
Camden Office:
2 Riverside Drive, Suite 503
Camden, New Jersey 08101
609.862.1582
FPAengineers.com
New Jersey • New York • Pennsylvania • Georgia

OWNER/DEVELOPER:
CROWN CASTLE
The Foundation for a Wireless World.

TITLE: Crown Castle Fiber LLC
Pole #: SO-PT-POLE-61986
288 WITHERSPOON STREET
PRINCETON, NJ
JURISDICTION: MUNICIPALITY OF PRINCETON

REVISIONS		
REV.	DATE	REVISION DESCRIPTION
3	06/25/24	REVISED PER PSE&G COMMENTS
4	03/05/25	REVISED PER COMMENTS & EME REPORT
5	03/31/25	REVISED PER PSE&G COMMENTS
6	06/05/25	REVISED PER COMMENTS
7	08/12/25	REVISED PER COMMENTS

DRAWN BY: D.R. CHECKED BY: A.R.C. APPROVED BY: P.J.T.

PROJECT NUMBER: 2438C.125.003
NODE ID: PRC-063
SCU # / CASCADE ID: 528020/PH6025BA_31LAB
DATE DRAWN: 09/13/2023
SHEET: 3 of 9

NOTE:
PREVIOUS SHORTER WOOD POLE TO BE
REMOVED, LEAVING ONLY ONE WOOD
POLE AT THE PROPOSED SITE LOCATION.



EXISTING POLE PHOTO
LOOKING NORTH

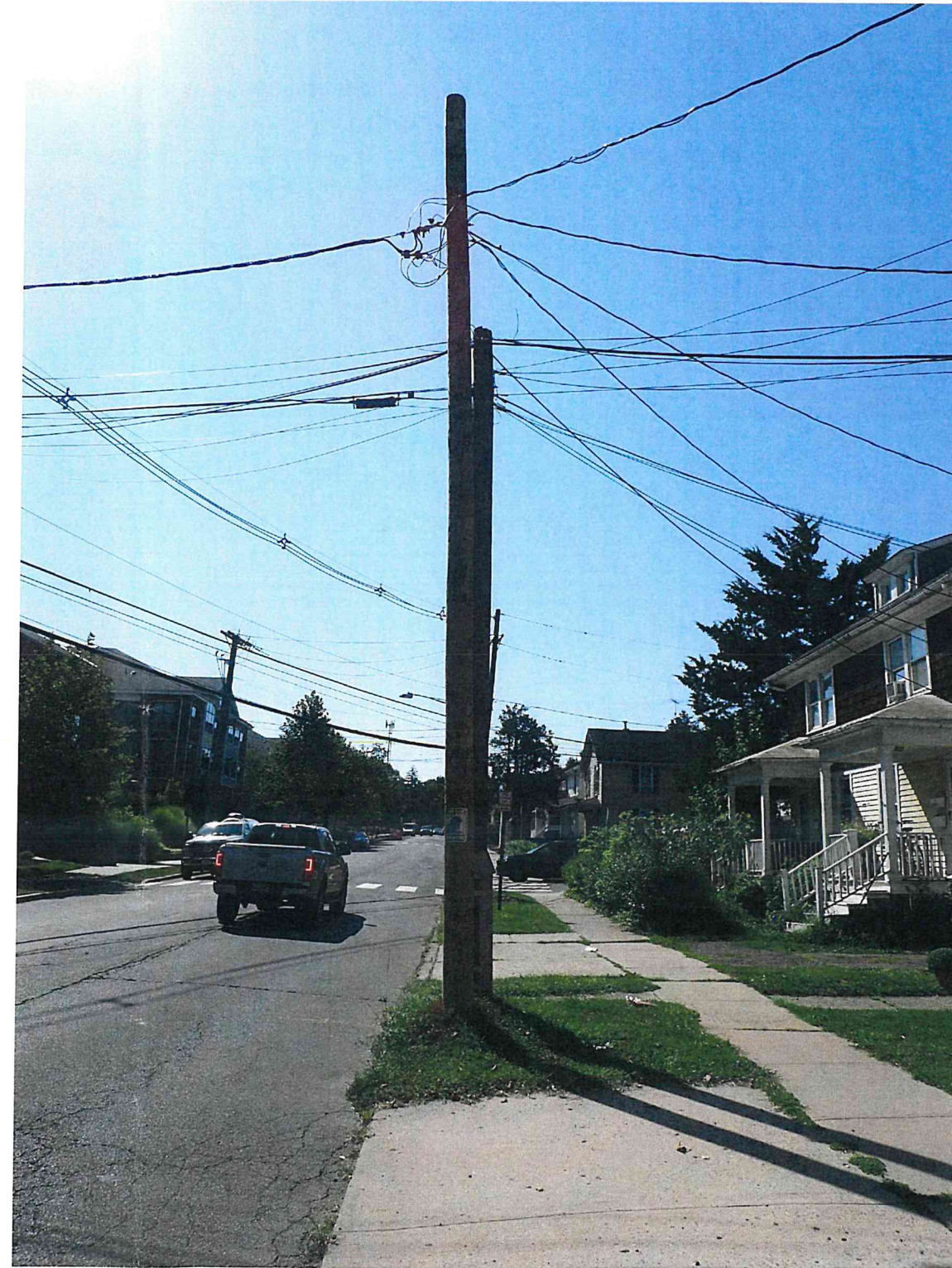

EXISTING POLE PHOTO
LOOKING SOUTH

Peter J. Tardy 08/12/2025
PETER J. TARDY, PE DATE
NEW JERSEY PROFESSIONAL ENGINEER LIC. NO. 41990

ENGINEER:



Camden Office:
2 Riverside Drive, Suite 503
Camden, New Jersey 08101
609.662.1582
FPAengineers.com

New Jersey New York Pennsylvania Georgia

OWNER/DEVELOPER:



The Foundation for a Wireless World.

TITLE: Crown Castle Fiber LLC
Pole #: SO-PT-POLE-61986
288 WITHERSPOON STREET
PRINCETON, NJ
JURISDICTION: MUNICIPALITY OF PRINCETON

REVISIONS		
REV.	DATE	REVISION DESCRIPTION
3	06/25/24	REVISED PER PSE&G COMMENTS
4	03/05/25	REVISED PER COMMENTS & EME REPORT
5	03/31/25	REVISED PER PSE&G COMMENTS
6	06/05/25	REVISED PER COMMENTS
7	08/12/25	REVISED PER COMMENTS

DRAWN BY:	CHECKED BY:	APPROVED BY:
D.R.	A.R.C.	P.J.T.

PROJECT NUMBER:	2438C.125.003
NODE ID:	PRC-063
SCU # / CASCADE ID:	528020/PH6025BA_31LAB
DATE DRAWN:	09/13/2023
SHEET:	4 of 9

NOTE:
PREVIOUS SHORTER WOOD POLE TO BE
REMOVED, LEAVING ONLY ONE WOOD
POLE AT THE PROPOSED SITE LOCATION.

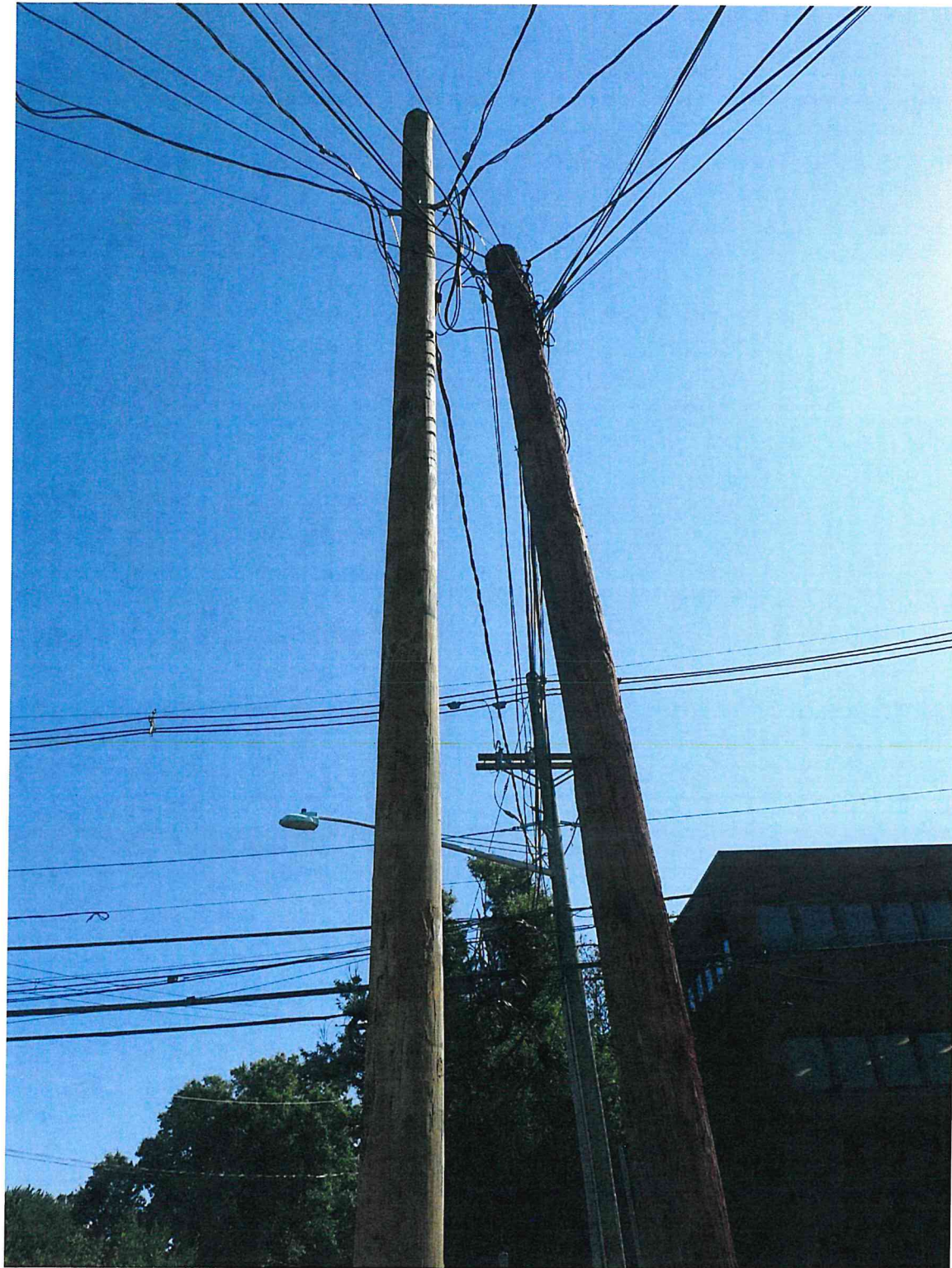

EXISTING POLE PHOTO
LOOKING EAST



EXISTING POLE PHOTO
LOOKING WEST

Peter J. Tardy 08/12/2025
PETER J. TARDY, PE DATE
NEW JERSEY PROFESSIONAL ENGINEER LIC. NO. 41990

ENGINEER:
FPA French & Parrello Associates
Camden Office:
2 Riverside Drive, Suite 503
Camden, New Jersey 08101
609.862.1582
FPAengineers.com
New Jersey New York Pennsylvania Georgia

OWNER/DEVELOPER:
CC CROWN CASTLE
The Foundation for a Wireless World.

TITLE: Crown Castle Fiber LLC
Pole #: S0-PT-POLE-61986
288 WITHERSPOON STREET
PRINCETON, NJ
JURISDICTION: MUNICIPALITY OF PRINCETON

REVISIONS		
REV.	DATE	REVISION DESCRIPTION
3	06/25/24	REVISED PER PSE&G COMMENTS
4	03/05/25	REVISED PER COMMENTS & EME REPORT
5	03/31/25	REVISED PER PSE&G COMMENTS
6	06/05/25	REVISED PER COMMENTS
7	08/12/25	REVISED PER COMMENTS

DRAWN BY:	CHECKED BY:	APPROVED BY:
D.R.	A.R.C.	P.J.T.

PROJECT NUMBER: 2438C.125.003
NODE ID: PRC-063
SCU # / CASCADE ID: 528020/PH6025BA_31LAB
DATE DRAWN: 09/13/2023
SHEET: 5 of 9

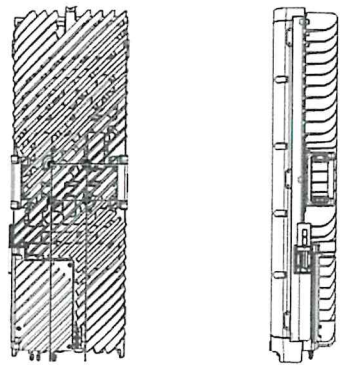

MECHANICAL SPECIFICATIONS:
HEIGHT: 31.3 IN.
WIDTH: 10.9 IN.
DEPTH: 5.9 IN.
WEIGHT: 67.2 LBS.

ERICSSON
RADIO 4455 B2/B25 B66A

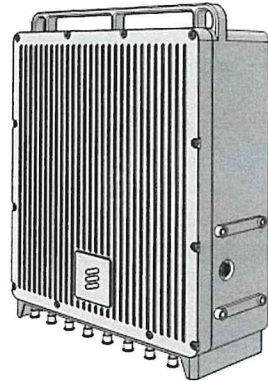

MECHANICAL SPECIFICATIONS:
HEIGHT: 18.1 IN.
WIDTH: 14.8 IN.
DEPTH: 5.7 IN.
WEIGHT: 50.9 LBS.

ERICSSON
RADIO 8863 B41 W/FAN



MECHANICAL SPECIFICATIONS:
HEIGHT: 4.33 IN.
WIDTH: 9.41 IN.
DEPTH: 3.51 IN.
WEIGHT: 7.9 LBS.

KAEIUS
DBCT156F1V12-1 DIPLEXER

BILL OF MATERIALS		
DESCRIPTION	QUANTITY	PART NUMBER
SHROUD	1	RAYCAP RAES-235418-C35
ANTENNA	1	AMPHENOL 2C6U2VT360X06F040s4
RADIO	1	ERICSSON 4455 B2/B25 B66A
RADIO	1	ERICSSON 8863 B41 W/FAN
DIPLEXER	1	KAEIUS DBCT156F1V12-1
MULTIPLEXER	1	ERICSSON OAD-9-S
PSU	1	PSU AC 08
FRONTHAUL	1	ERICSSON 6585
DISCONNECT	1	RAYCAP RSD-FMC-Z16MS-21NN
METER	1	MILBANK #U8569-YL-PSE&G-DES
DISCONNECT	1	SQUARE D QO2-4L70RB
ANTENNA POLE TOP MOUNTING BRACKET	1	CONCEALFAB 007960-1 POLE TOP EXTENSION W/ 900192 TOP BRACKET
1.25" SCH 80 PVC CONDUIT (TO METER)	1	
1" (MIN) TITAN 2 UL LFMC (OR EQUAL) (TO DISCONNECT)	1	
1" (MIN) OFFSET ELBOW CONNECTOR (DIS TO LOAD CENTER)	1	
#4 AWG SERVICE CONDUCTORS (RISER TO METER/METER TO DIS)	6	
#6 AWG (MIN) POWER CONDUCTORS (DIS TO LOAD CENTER)	3	
#8 AWG (MIN) GND (DIS TO LOAD CENTER)	1	
#6 AWG (MIN) BONDING JUMPERS	2	
KENNY CLAMP	1	
LED INDICATOR	1	
MAIN DISCONNECT SIGN	1	
"BLUE" POLE WORKER SIGN	1	
"YELLOW" CAUTION SIGN	1	
ARC FLASH WARNING SIGN	1	
SMALL CELL SITE SIGN	1	



MECHANICAL SPECIFICATIONS:
HEIGHT: 24 IN.
DIAMETER: 14.6 IN.
WEIGHT: 28.0 LBS.

AMPHENOL
2C6U2VT360X06F040s4
ANTENNA

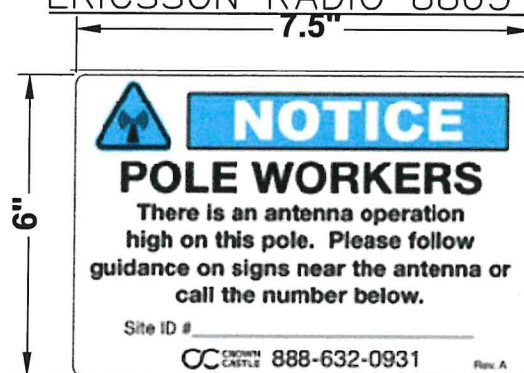

NOTES:
1. POLE WORKER SIGNAGE ATTACHED ON:
WOOD POLES = SIGN ON ALUMINUM WITH STAINLESS STEEL SCREWS.
METAL POLES = ADHESIVE VINYL OR PLACARD STRAPPED WITH STAINLESS STEEL TIES.
CONCRETE/COMPOSITE = PLACARD STRAPPED WITH STAINLESS STEEL TIES.
FIBERGLASS = PLACARD STRAPPED WITH STAINLESS STEEL TIES.
2. AFFIX SIGN TO THE STRUCTURE AS PER EME REPORT.

POLE WORKER
"BLUE" NOTICE SIGN

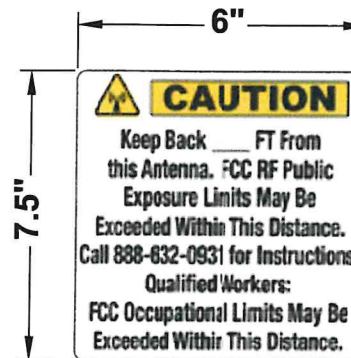

NOTES:
1. ANTENNA SIGNAGE ATTACHED ON:
WOOD POLES = SIGN ON ALUMINUM WITH STAINLESS STEEL SCREWS.
METAL POLES = ADHESIVE VINYL OR PLACARD STRAPPED WITH STAINLESS STEEL TIES.
CONCRETE/COMPOSITE = PLACARD STRAPPED WITH STAINLESS STEEL TIES.
FIBERGLASS = PLACARD STRAPPED WITH STAINLESS STEEL TIES.
2. AFFIX SIGN TO THE STRUCTURE AS PER EME REPORT.
3. THE SIGN MUST BE COMPLETELY READABLE FROM OUTSIDE THE DANGER ZONE.

RF "YELLOW" CAUTION SIGN
(BELOW ANTENNAS)

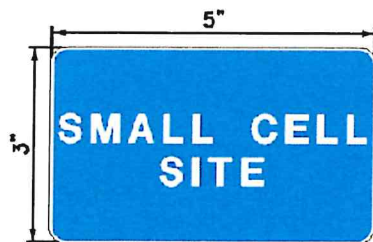

NOTES:
1. SIGNAGE ATTACHED ON:
WOOD POLES = PLACARD TO BE VINYL WITH UV-STABLE INK, ATTACHED WITH STAINLESS STEEL SCREWS.
METAL POLES = ADHESIVE VINYL OR VINYL PLACARD WITH UV-STABLE INK, STRAPPED WITH STAINLESS STEEL TIES.
CONCRETE/COMPOSITE/FIBERGLASS = PLACARD TO BE VINYL WITH UV-STABLE INK, STRAPPED WITH STAINLESS STEEL TIES.
2. AFFIX SIGN TO THE STRUCTURE IN PROXIMITY TO THE METER AND/OR DISCONNECT.

SMALL CELL SIGN

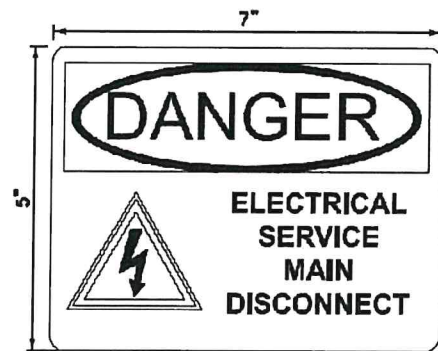

NOTES:
1. SIGN TO BE INSTALLED ON DISCONNECT BOX.
2. SIGN ON VINYL WITH ADHESIVE BACKING.
3. NO BACKUP DC POWER SUPPLY IS AVAILABLE FOR THIS SYSTEM.

DISCONNECT WARNING SIGN

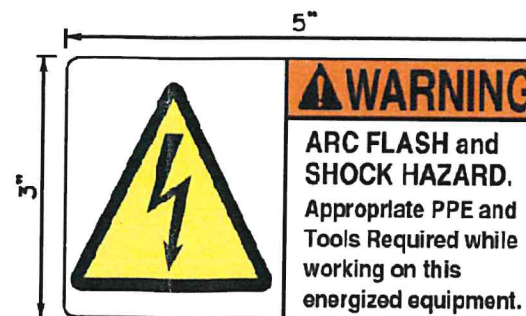

NOTES:
1. SIGN TO BE INSTALLED ON LOAD CENTER.
2. LABEL MUST BE PERMANENTLY AFFIXED AND WATERPROOF.
3. VALUES MUST BE HANDWRITTEN ON LABEL IN LEGIBLE PERMANENT MARKER.

ARC FLASH WARNING SIGN

Peter J. Tardy
PETER J. TARDY, PE
NEW JERSEY PROFESSIONAL ENGINEER
LIC. NO. 41990
DATE: 08/12/2025

FPA
FRENCH & PARRELLO ASSOCIATES
Camden Office:
2 Riverside Drive, Suite 503
Camden, New Jersey 08101
609.862.1562
FPAengineers.com
New Jersey New York Pennsylvania Georgia

CROWN CASTLE
The Foundation for a Wireless World.

TITLE: Crown Castle Fiber LLC
Pole #: S0-PT-POLE-61986
288 WITHERSPOON STREET
PRINCETON, NJ
JURISDICTION: MUNICIPALITY OF PRINCETON

REVISIONS		
REV.	DATE	REVISION DESCRIPTION
3	06/25/24	REVISED PER PSE&G COMMENTS
4	03/05/25	REVISED PER COMMENTS & EME REPORT
5	03/31/25	REVISED PER PSE&G COMMENTS
6	06/05/25	REVISED PER COMMENTS
7	08/12/25	REVISED PER COMMENTS

DRAWN BY: D.R. CHECKED BY: A.R.C. APPROVED BY: P.J.T.

PROJECT NUMBER: 2438C.125.003

NODE ID: PRC-063

SCU # / CASCADE ID: 528020/PH6025BA_31LAB

DATE DRAWN: 09/13/2023

SHEET: 7 of 9

Scenario Name:-
Scenario 048

Project:-
Trenton, NJ

Designed by:- Prashant Patel
Customer:- T-Mobile

Date Created:- 04/13/2023
Revision:- 1

Cluster Name:- Philly County
Sheet:- 048



New Antenna

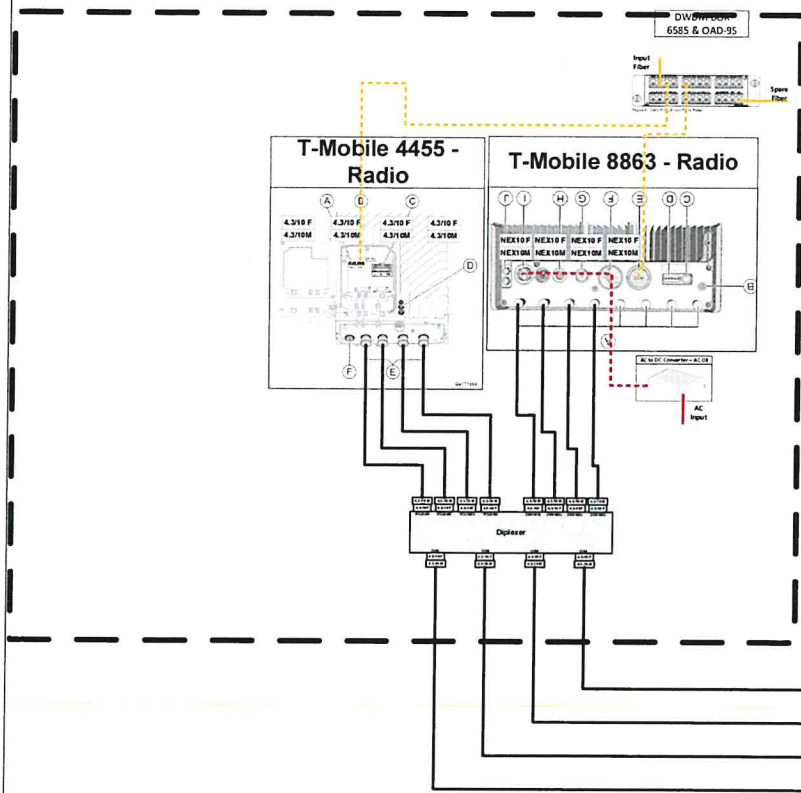
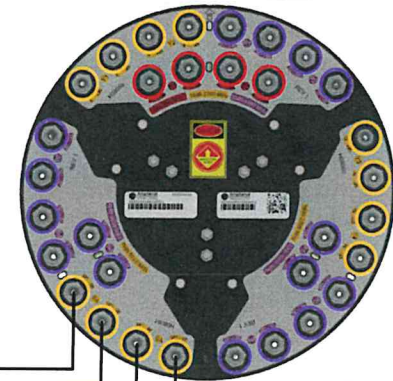

T-Mobile Path 4 - 1900,2100 & 2500MHz
T-Mobile Path 3 - 1900,2100 & 2500MHz
T-Mobile Path 2 - 1900,2100 & 2500MHz
T-Mobile Path 1 - 1900,2100 & 2500MHz

Carrier	Band (MHz)	Band Color	Description	Path 1	Path 2	Comments
Verizon	700	1x Red	Brown	Brown/Brown		
	850	2x Red	Brown	Brown/Brown		Alternatively named Cellular Band
	1900	3x Red	Brown	Brown/Brown		Alternatively named PCS Band
	2100	4x Red	Brown	Brown/Brown		Alternatively named AWS or 1700 Band
AT&T	700	1x Blue	Brown	Brown/Brown		
	850	2x Blue	Brown	Brown/Brown		Alternatively named Cellular Band
	1900	3x Blue	Brown	Brown/Brown		Alternatively named PCS Band
	2100	4x Blue	Brown	Brown/Brown		Alternatively named AWS or 1700 Band
T-Mobile	700	1x Green	Brown	Brown/Brown		Alternatively named WCS Band
	1900	3x Green	Brown	Brown/Brown		Alternatively named PCS Band
	2100	4x Green	Brown	Brown/Brown		Alternatively named AWS or 1700 Band
	2300	5x Blue	Brown	Brown/Brown		Alternatively named WCS Band
Metro	2100	4x Purple	Brown	Brown/Brown		Alternatively named AWS or 1700 Band
	2300	5x Yellow	Brown	Brown/Brown		Alternatively named WCS Band
Sprint	700	1x Yellow	Brown	Brown/Brown		
	850	2x Yellow	Brown	Brown/Brown		Alternatively named Cellular Band
	1900	3x Yellow	Brown	Brown/Brown		Alternatively named PCS Band
	2100	4x Yellow	Brown	Brown/Brown		Alternatively named AWS or 1700 Band
	2300	5x Yellow	Brown	Brown/Brown		Alternatively named WCS Band
	2500	6x Yellow	Brown	Brown/Brown		Alternatively named WCS Band

FREQUENCY	ARRAY	CONNECTOR	CONNECTOR TYPE	FREQUENCY	ARRAY	CONNECTOR	CONNECTOR TYPE
3300-4200 MHz	P1	17-18	(2x) 4.3-10 Female	696-960 MHz	R1	1-2	(2x) 4.3-10 Female
3300-4200 MHz	P2	19-20	(2x) 4.3-10 Female	696-960 MHz	R2	3-4	(2x) 4.3-10 Female
3300-4200 MHz	P3	21-22	(2x) 4.3-10 Female	1695-2700 MHz	Y1	5-6	(2x) 4.3-10 Female
3300-4200 MHz	P4	23-24	(2x) 4.3-10 Female	1695-2700 MHz	Y2	7-8	(2x) 4.3-10 Female
3300-4200 MHz	P5	25-26	(2x) 4.3-10 Female	1695-2700 MHz	Y3	9-10	(2x) 4.3-10 Female
3300-4200 MHz	P6	27-28	(2x) 4.3-10 Female	1695-2700 MHz	Y4	11-12	(2x) 4.3-10 Female
3300-4200 MHz	P7	29-30	(2x) 4.3-10 Female	1695-2700 MHz	Y5	13-14	(2x) 4.3-10 Female
3300-4200 MHz	P8	31-32	(2x) 4.3-10 Female	1695-2700 MHz	Y6	15-16	(2x) 4.3-10 Female

Peter J. Tardy 08/12/2025
DATE
PETER J. TARDY, PE
NEW JERSEY PROFESSIONAL ENGINEER LIC. NO. 41990

ENGINEER:
FPA
FRENCH & PARELLO ASSOCIATES
Camden Office:
2 Riverside Drive, Suite 503
Camden, New Jersey 08101
609.882.1582
FPAengineers.com
New Jersey New York Pennsylvania Georgia

OWNER/DEVELOPER:
CROWN CASTLE
The Foundation for a Wireless World.

TITLE: Crown Castle Fiber LLC
Pole #: SO-PT-POLE-61986
288 WITHERSPOON STREET
PRINCETON, NJ
JURISDICTION: MUNICIPALITY OF PRINCETON

REVISIONS

REV.	DATE	REVISION DESCRIPTION
3	06/25/24	REVISED PER PSE&G COMMENTS
4	03/05/25	REVISED PER COMMENTS & EME REPORT
5	03/31/25	REVISED PER PSE&G COMMENTS
6	06/05/25	REVISED PER COMMENTS
7	08/12/25	REVISED PER COMMENTS

DRAWN BY: D.R. CHECKED BY: A.R.C. APPROVED BY: P.J.T.

PROJECT NUMBER: 2438C.125.003
NODE ID: PRC-063
SCU # / CASCADE ID: 528020/PH6025BA_31LAB
DATE DRAWN: 09/13/2023
SHEET: 8 OF 9

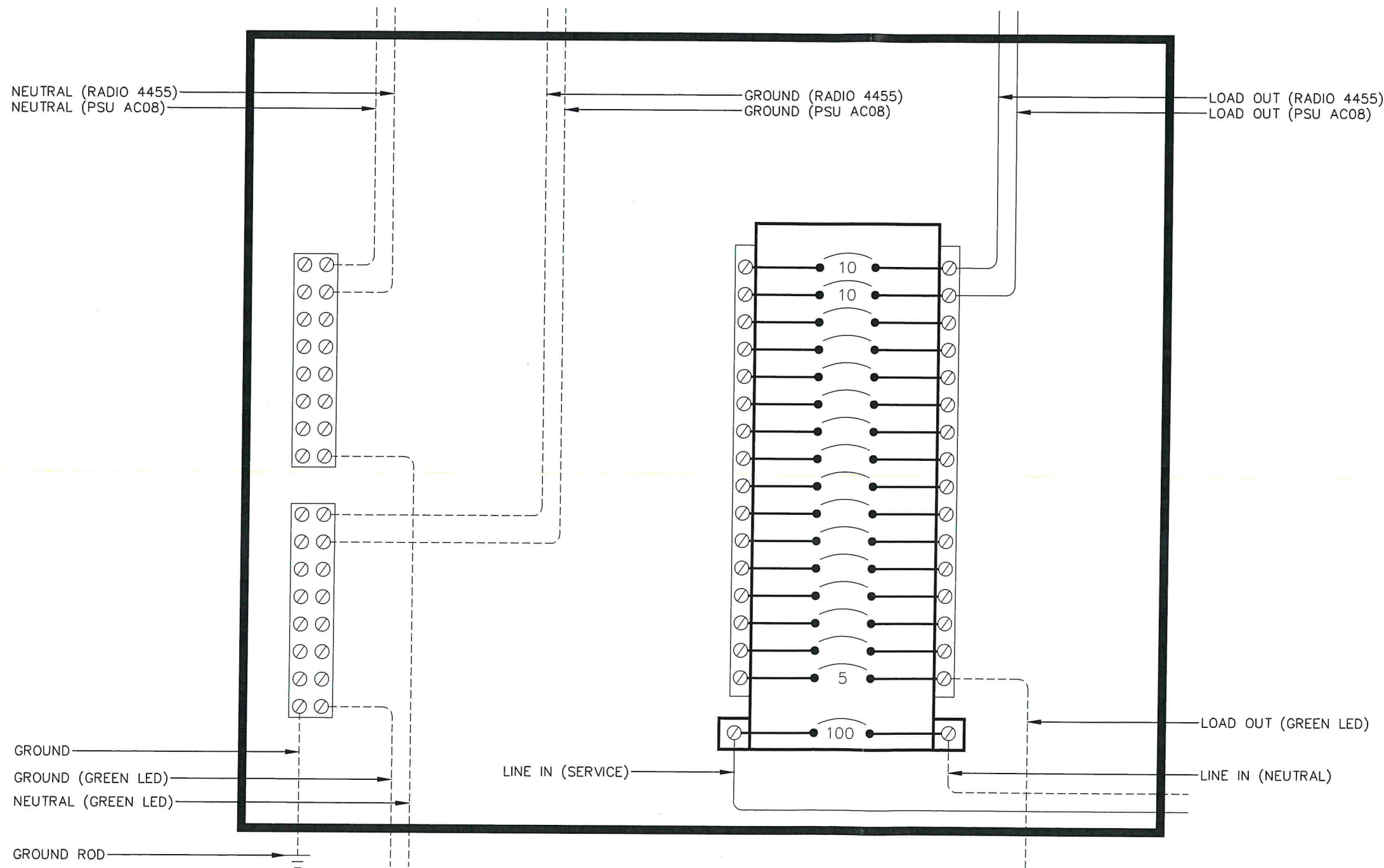

Peter J. Tardy 08/12/2025
 PETER J. TARDY, PE
 NEW JERSEY PROFESSIONAL ENGINEER LIC. NO. 41990

ENGINEER:

Camden Office:
 2 Riverside Drive, Suite 503
 Camden, New Jersey 08101
 609.862.1582
 FPAengineers.com
 New Jersey New York Pennsylvania Georgia

OWNER/DEVELOPER:

The Foundation for a Wireless World.

TITLE: Crown Castle Fiber LLC
 Pole #: S0-PT-POLE-61986
 288 WITHERSPOON STREET
 PRINCETON, NJ
 JURISDICTION: MUNICIPALITY OF PRINCETON

REVISIONS

REV.	DATE	REVISION DESCRIPTION
3	06/25/24	REVISED PER PSE&G COMMENTS
4	03/05/25	REVISED PER COMMENTS & EME REPORT
5	03/31/25	REVISED PER PSE&G COMMENTS
6	06/05/25	REVISED PER COMMENTS
7	08/12/25	REVISED PER COMMENTS

DRAWN BY:	CHECKED BY:	APPROVED BY:
D.R.	A.R.C.	P.J.T.

PROJECT NUMBER:	2438C.125.003
NODE ID:	PRC-063
SCU # / CASCADE ID:	528020/PH6025BA_31LAB
DATE DRAWN:	09/13/2023
SHEET:	9 of 9

SITE LICENSE AGREEMENT
1288 Stuart Road

This Site License Agreement is made this _____ day of _____, 2026 by and between the MUNICIPALITY OF PRINCETON (“Licensor”) and CROWN CASTLE Fiber LLC, a Delaware Limited Liability Company (“Licensee”).

1. Rights of Way Use Agreement. As referenced in Exhibit 2 of a certain Rights of Way Use Agreement between Licensor and Licensee ("Agreement"), Licensee has submitted a Site License Application pursuant to the Agreement, and Licensor has reviewed the application and grants approval subject to the terms of this Site License Agreement. All of the terms and conditions of the Agreement are incorporated hereby by reference and made a part hereof without the necessity of repeating or attaching the Agreement. In the event of a contradiction or inconsistency between the terms of the Agreement and this Site License Agreement, the terms of this Site License Agreement shall govern. Capitalized terms used in this Site License Agreement shall have the same meaning ascribed to them in the Agreement unless otherwise indicated herein.
2. Project Description and Locations. Licensee shall have the right to install and attach Wireless Installations on, under, and above the public right of way owned or controlled by Licensor, on, in and adjacent to the specific Structure and Infrastructure as identified and described in Exhibit 1 attached hereto (collectively the "Licensed Site").
3. Term. The Site License Term of this Site License Agreement shall be as set forth in Section 2 of the Agreement.
4. Fee. The Fee shall be in the amount and otherwise payable in accordance with the Agreement as set forth in Section 4 of the Agreement.
5. Special Provisions, If Any (Specific to the Licensed Site).

[SIGNATURES APPEAR ON FOLLOWING PAGE]

LICENSOR:

MUNICIPALITY OF PRINCETON

By: _____

Print Name:

Title:

Date: _____

LICENSEE:

Crown Castle Fiber LLC
a New York Limited Liability Company

By: _____

Print Name:

Title:

Date: _____

EXHIBITS: Licensed Site, Wireless Installation Equipment List and Plans

EXHIBIT 1 TO SITE LICENSE AGREEMENT

Licensed Site, Wireless Installation Equipment List and Plans

Licensee Wireless Installation Reference: **PCT-006**

SCU: **402142**

Site Name: **1288 Stuart Road**

FA / USID:

PTN / PACE:

Structure pole number: **NT**

Structure Latitude and Longitude (Approximate): **40.367635, -74.689228**

Wireless Installation Equipment List: Please see attached construction drawings referenced below:

Crown Castle Fiber LLC | 1288 Stuart Road | Jurisdiction: Municipality of Princeton | Proposed Small Cell Site dated
11/02/2023 last revised 12/18/2025



INDEX TO SHEETS	
DWG #	DRAWING TITLE
1	COVER SHEET
2	PROPOSED POLE CONFIGURATION
3	PROPOSED POLE LOCATION PHOTOS (N&S)
4	PROPOSED POLE LOCATION PHOTOS (E&W)
5	PROPOSED EQUIPMENT DETAILS
6	PROPOSED ANTENNA & RADIO DETAILS
7	WIRING DIAGRAM
8	DISCONNECT BOX

PROPOSED POLE CLASS: 2

Crown Castle Fiber LLC
1288 STUART ROAD
JURISDICTION: MUNICIPALITY OF PRINCETON
PROPOSED SMALL CELL SITE

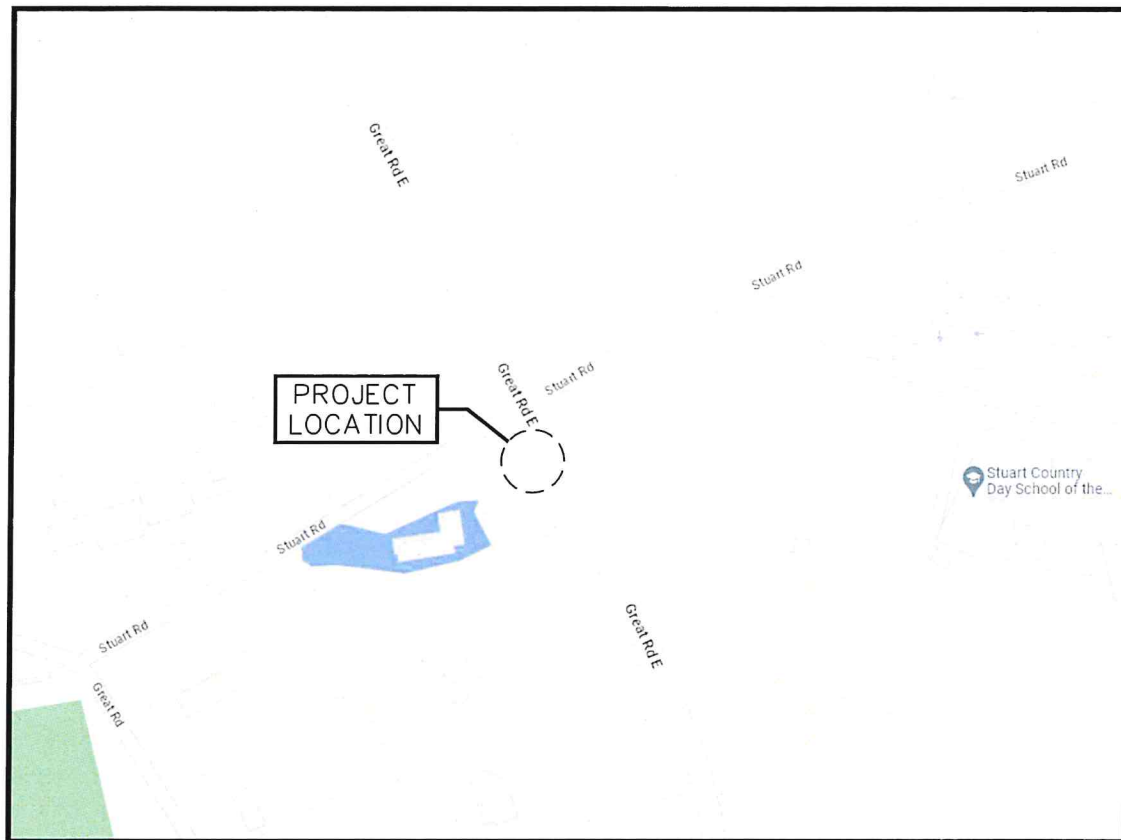

NOT TO SCALE



NOT TO SCALE

LOCATION MAP

LATITUDE: 40.367635°N
LONGITUDE: -74.689228°W
BLOCK: 3702, LOT 1

NODE PLACEMENT

1288 STUART ROAD
PROPOSED CROWN CASTLE WOOD POLE
ON THE SOUTHWEST CORNER OF
STUART ROAD AND GREAT ROAD E.
POLE ID: NT



Peter J Tardy
PETER J TARDY, PE
NEW JERSEY PROFESSIONAL ENGINEER
DATE: 12/18/2025
NJ LIC NO 41990



TITLE:
Crown Castle Fiber LLC
1288 STUART ROAD
PRINCETON, NJ
JURISDICTION: MUNICIPALITY OF PRINCETON

REVISIONS		
REV.	DATE	REVISION DESCRIPTION
2	02/21/24	REVISED PER COMMENTS
3	11/27/24	REVISED ANTENNA MODEL
4	09/10/25	REVISED POLE LOCATION
5	10/15/25	REVISED POLE LOCATION
6	12/18/25	ISSUED AS FINAL

DRAWN BY:	CHECKED BY:	APPROVED BY:
ARC	ARC	PJT

PROJECT NUMBER: 2438C.129.003
NODE ID: PCT-006
SCU #: 402142
DATE DRAWN: 11/02/2023
SHEET: 1 of 8

- NOTES:**
- POINT OF CONTACT FOR POWER AND TELCO TO BE DETERMINED PENDING UTILITY COORDINATION.
 - PROPOSED SECONDARY AND FIBER LOCATION AND HEIGHT TBD PENDING UTILITY COORDINATION.

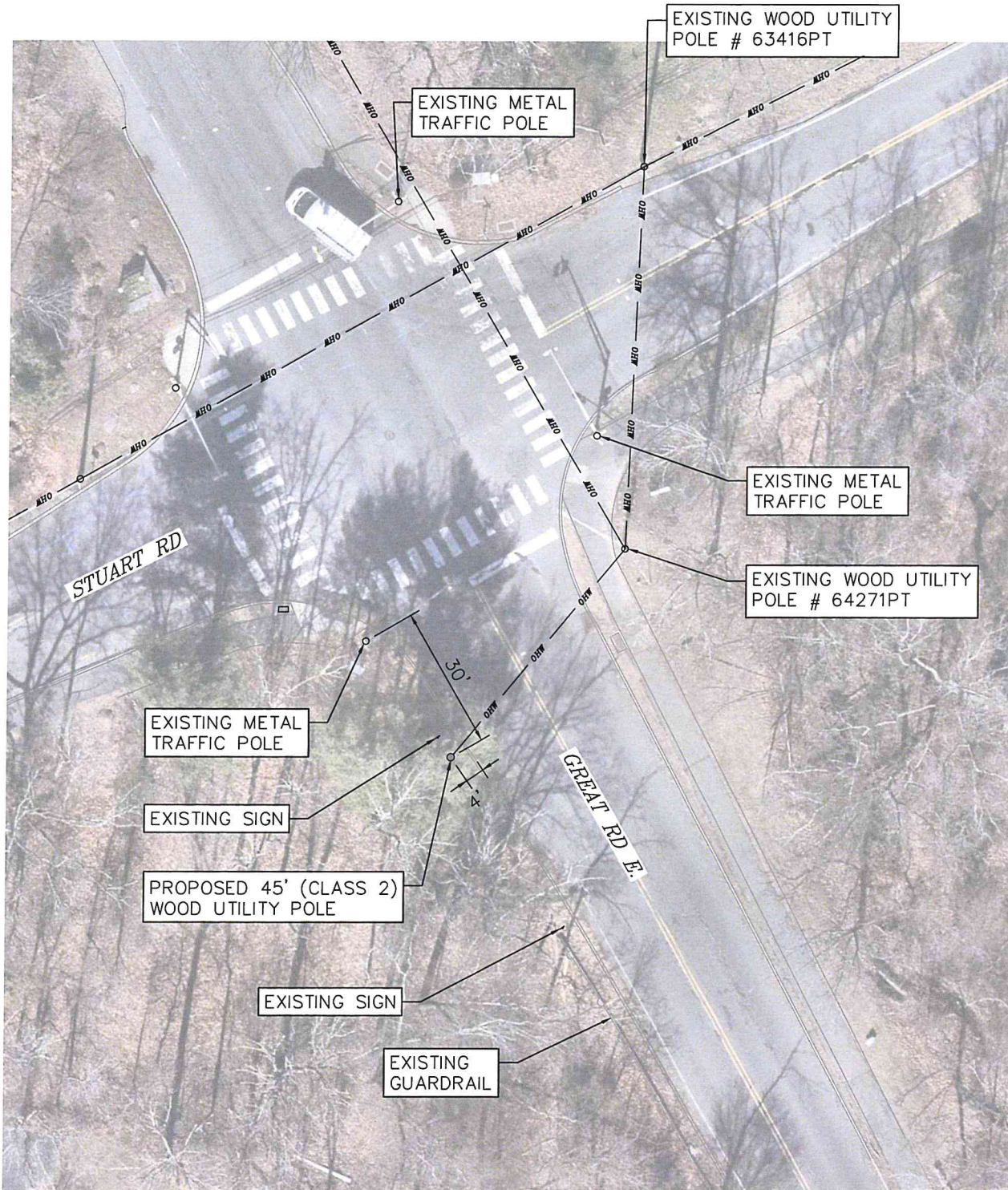

NOT TO SCALE

PROPOSED POLE LOCATION

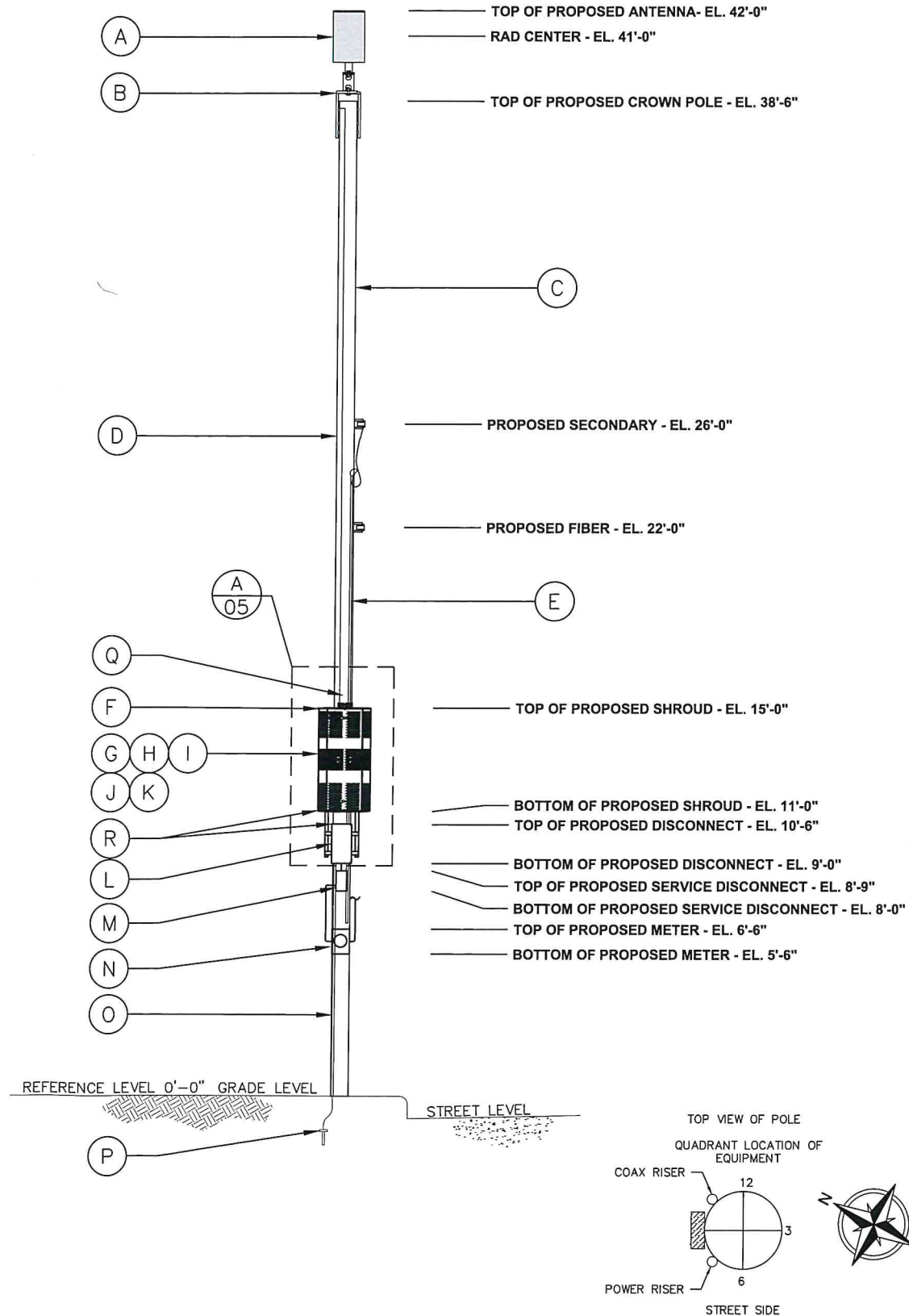

PROPOSED POLE DETAIL
LOOKING NORTHWEST

- PROPOSED ANTENNA:
(1) JMA WIRELESS CYL2016R-2xy
24.0' x 14.6" (HxW) - 26 LBS
- PROPOSED POLE TOP MOUNT:
(1) NYM MK-1B3
TO BE THRU-BOLTED TO POLE
MOUNT COLOR: BROWN
- INSTALL NEW 45' CLASS 2 WOOD UTILITY POLE
TOP HEIGHT = 38'-6" (AGL)
- INSTALL 3" PVC RISER U-GUARD:
PROPOSED #4 AWG GROUND WIRE AND COAX/FIBER CABLES
TO BE ROUTED WITHIN
- INSTALL 1.25" PVC SCH. 80 POWER RISER CONDUIT FROM METER TO
SECONDARY
- INSTALL SHROUD CABINET:
RAYCAP RAS-235418-C35
48.0' x 24.0' x 24.0" (HxWxD) - 433 LBS
EQUIPMENT COLOR: BROWN
TO BE THRU-BOLTED TO POLE
- INSTALL RADIO UNIT WITHIN NEW SHROUD:
(1) SAMSUNG RADIO RFV01U-D1A B2 B66
18.73' x 15.96' x 10.04" (HxWxD) - 84.4 LBS
- INSTALL RADIO UNIT WITHIN NEW SHROUD:
(1) SAMSUNG RADIO RFV01U-D2A B5 B13
19.73' x 15.0' x 8.1" (HxWxD) - 70.3 LBS
- INSTALL DIPLEXER WITHIN NEW SHROUD:
(1) COMMSCOPE SDX1250-43
4.17' x 6.93' x 2.91" (HxWxD) - 6.17 LBS
- INSTALL DIPLEXER WITHIN NEW SHROUD:
(1) COMMSCOPE CBC78-DS-43
6.59' x 5.93' x 2.89" (HxWxD) - 5.95 LBS
- INSTALL RECTIFIER WITHIN NEW SHROUD:
(1) DELTA ESR-48/38A U-5
15.5' x 11.3' x 3.7" (HxWxD) - 21.0 LBS
- INSTALL 100A DISCONNECT:
(1) RAYCAP RSC-FWC-216MS-21NY
8.25' x 10' x 6.05" (HxWxD) - 23.6 LBS
EQUIPMENT COLOR: BROWN
TO BE MOUNTED BELOW EQUIPMENT SHROUD
- INSTALL SERVICE DISCONNECT:
(1) SQUARE D Q02-4L70RB
9.37' x 4.88" (HxW) - 5.05 LBS
EQUIPMENT COLOR: BROWN
TO BE MOUNTED BELOW 100A DISCONNECT
- INSTALL POWER METER:
(1) MILBANK UB568-T-PSE&G-DES
11.5' x 8.1' x 3.3" (HxWxD)
EQUIPMENT COLOR: BROWN
TO BE MOUNTED BELOW 100A DISCONNECT
- INSTALL 1" PVC U-GUARD:
PROPOSED #4 AWG GROUND WIRE ROUTED WITHIN
- INSTALL 8' GROUND ROD
- INSTALL (2) "YELLOW" CAUTION SIGNS ABOVE EQUIPMENT SHROUD
ON EITHER SIDE OF POLE
- INSTALL SITE ID SIGN ON BOTTOM LEFT CORNER OF EQUIPMENT
SHROUD AND INSIDE DOOR OF DISCONNECT

Peter J Tardy
12/18/2025
DATE

PETER J TARDY, PE
NEW JERSEY PROFESSIONAL ENGINEER
NJ LIC NO 41990

ENGINEER:

Corporate Office:
1800 Rt 34, Suite 101
Wall, New Jersey 07719
732.312.9800
FPAengineers.com
New Jersey • New York • Pennsylvania • Massachusetts

OWNER/DEVELOPER:

The Foundation for a Wireless World.

TITLE:
Crown Castle Fiber LLC
1288 STUART ROAD
PRINCETON, NJ
JURISDICTION: MUNICIPALITY OF PRINCETON

REVISIONS		
REV.	DATE	REVISION DESCRIPTION
2	02/21/24	REVISED PER COMMENTS
3	11/27/24	REVISED ANTENNA MODEL
4	09/10/25	REVISED POLE LOCATION
5	10/15/25	REVISED POLE LOCATION
6	12/18/25	ISSUED AS FINAL

DRAWN BY:	CHECKED BY:	APPROVED BY:
ARC	ARC	PJT

PROJECT NUMBER:	2438C.129.003
NODE ID:	PCT-006
SCU #:	402142
DATE DRAWN:	11/02/2023
SHEET:	2 of 8

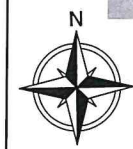

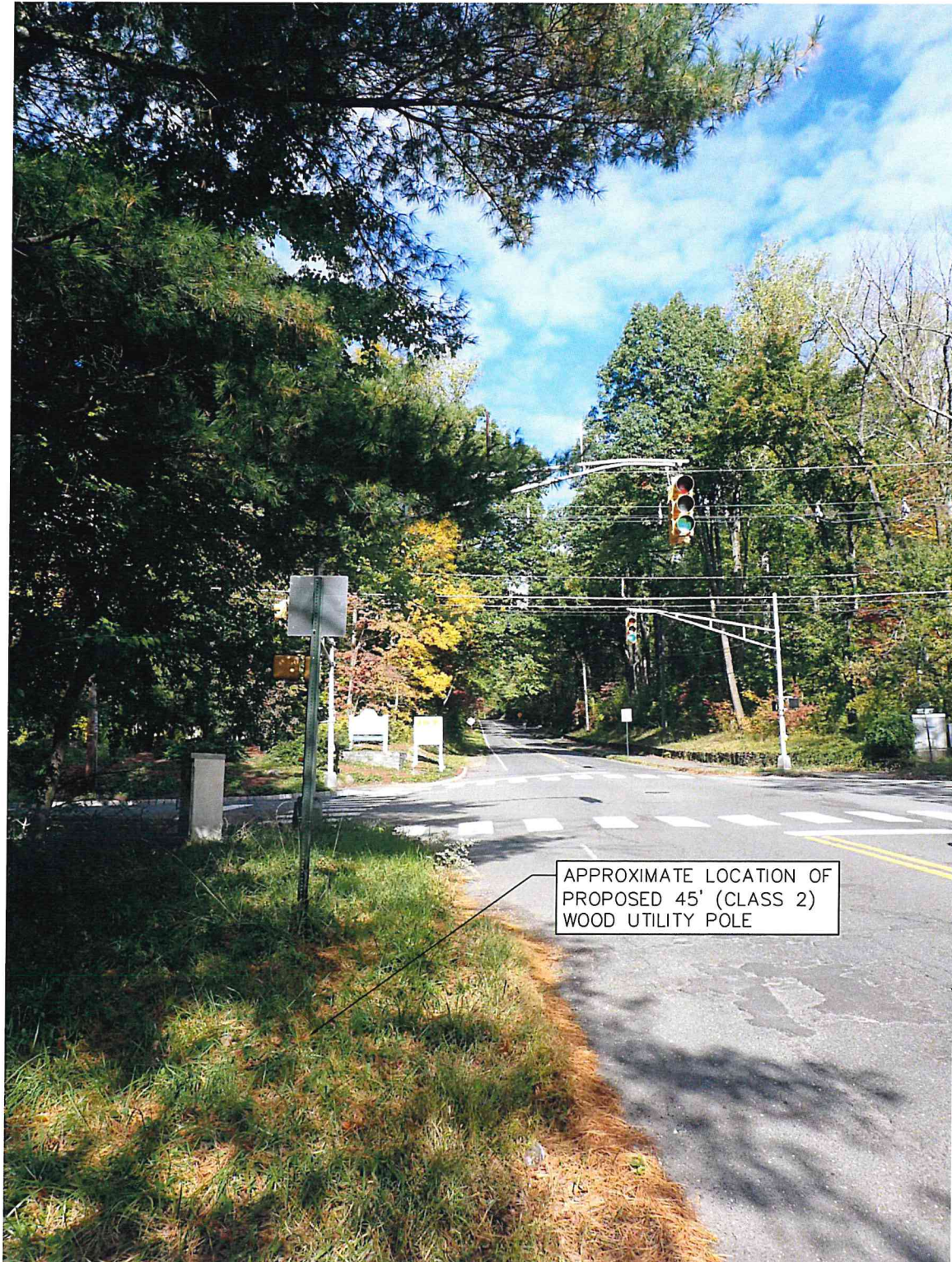

PROPOSED POLE PHOTO
LOOKING NORTH



PROPOSED POLE PHOTO
LOOKING SOUTH

Peter J Tardy
PETER J TARDY, PE
NEW JERSEY PROFESSIONAL ENGINEER
DATE: 12/18/2025
NJ LIC NO 41990

ENGINEER:
FPA
FRENCH & PARRELLO
ASSOCIATES
Corporate Office:
1800 Rt 34, Suite 101
Wall, New Jersey 07719
732.312.9800
FPAengineers.com
New Jersey • New York • Pennsylvania • Massachusetts

OWNER/DEVELOPER:
CC CROWN CASTLE
The Foundation for a Wireless World.

TITLE:
Crown Castle Fiber LLC
1288 STUART ROAD
PRINCETON, NJ
JURISDICTION: MUNICIPALITY OF PRINCETON

REVISIONS		
REV.	DATE	REVISION DESCRIPTION
2	02/21/24	REVISED PER COMMENTS
3	11/27/24	REVISED ANTENNA MODEL
4	09/10/25	REVISED POLE LOCATION
5	10/15/25	REVISED POLE LOCATION
6	12/18/25	ISSUED AS FINAL

DRAWN BY:	CHECKED BY:	APPROVED BY:
ARC	ARC	PJT
PROJECT NUMBER:	2438C.129.003	
NODE ID:	PCT-006	
SCU #:	402142	
DATE DRAWN:	11/02/2023	
SHEET:	3 of 8	



PROPOSED POLE PHOTO
LOOKING EAST

Peter J Tardy
12/18/2025
DATE

PETER J TARDY, PE
NEW JERSEY PROFESSIONAL ENGINEER
NJ LIC NO 41990

ENGINEER:



Corporate Office:
1800 Rt 34, Suite 101
Wall, New Jersey 07719
732.312.9800

FPAengineers.com

New Jersey • New York • Pennsylvania • Massachusetts

OWNER/DEVELOPER:



TITLE:

Crown Castle Fiber LLC
1288 STUART ROAD
PRINCETON, NJ
JURISDICTION: MUNICIPALITY OF PRINCETON

REVISIONS

REV.	DATE	REVISION DESCRIPTION
2	02/21/24	REVISED PER COMMENTS
3	11/27/24	REVISED ANTENNA MODEL
4	09/10/25	REVISED POLE LOCATION
5	10/15/25	REVISED POLE LOCATION
6	12/18/25	ISSUED AS FINAL

DRAWN BY:	CHECKED BY:	APPROVED BY:
ARC	ARC	PJT

PROJECT NUMBER: 2438C.129.003

NODE ID: PCT-006

SCU #: 402142

DATE DRAWN: 11/02/2023

SHEET: 4 OF 8

REV	DESCRIPTION	DATE	DRWN BY	APP
0	RELEASED	10/30/2024	JM	

7.745 24.000 44.282 24.000 48.000 6.546

REMOVABLE FAN TRAY (OPTIONAL)

3 POINT QUARTER TURN LATCH WITH PADLOCK

DETAIL A SCALE 0.25: 1

NOTES:
1. MATL: ALUMINUM ENCL. W. STEEL FRAME.
2. COLOR: AS REQUIRED
3. WEIGHT: APPROX. 157LBS (WITHOUT RADIOS)
4. WEIGHT: APPROX. 433LBS (WITH RADIOS)
5. ACTIVE COOLING AS SHOWN.
6. VOLUME: 16 CU FT

RAYCAP	RAES-235418-C35	7/25/2023	46 Suters St, Kearny, NJ 07032
DESIGNER	DESIGNED BY	DATE	PHONE
PROJECT	PROJECT NO.	REV	REV
ISSUED BY	ISSUED DATE	ISSUED FOR	ISSUED FOR

FINAL PLACEMENT OF COMPONENTS PENDING CABLE MANAGEMENT AND THERMAL ANALYSIS

DETAIL A
RAYCAP RAES-235418-C35
SHROUD



MECHANICAL SPECIFICATIONS:
HEIGHT: 15.5 IN.
WIDTH: 11.3 IN.
DEPTH: 3.7 IN.
WEIGHT: 21.0 LBS.

DELTA
RECTIFIER ESR-48/38A U-S

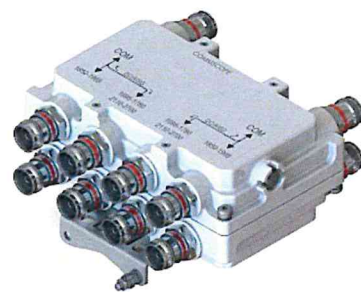

MECHANICAL SPECIFICATIONS:
HEIGHT: 4.17 IN.
WIDTH: 6.93 IN.
DEPTH: 2.91 IN.
WEIGHT: 6.17 LBS.

COMMSCOPE
DIPLEXER SDX1926Q-43



MECHANICAL SPECIFICATIONS:
HEIGHT: 6.38 IN.
WIDTH: 6.93 IN.
DEPTH: 2.89 IN.
WEIGHT: 5.95 LBS.

COMMSCOPE
DIPLEXER CBC78-DS-43



MECHANICAL SPECIFICATIONS:
HEIGHT: 11.5 IN.
WIDTH: 8.0 IN.
DEPTH: 3.3 IN.

MILBANK U8569-YL-PSEG-DES
METER PAN



MECHANICAL SPECIFICATIONS:
HEIGHT: 9.37 IN.
WIDTH: 4.88 IN.
WEIGHT: 5.05 LBS.

SQUARE D Q02-4L70RB
DISCONNECT

FRONT SIDE

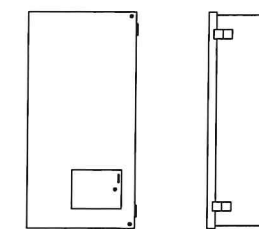

TOP



LED POWER ON STATUS INDICATOR (SEE NOTE)

NOTES:
1. NEMA 4 RATED, UL LISTED
2. CONTRACTOR SHALL ORDER BROWN ENCLOSURE COLOR TO MATCH EXISTING/PROPOSED STRUCTURE

MECHANICAL SPECIFICATIONS:
HEIGHT: 18.25 IN.
WIDTH: 9.10 IN.
DEPTH: 6.05 IN.
WEIGHT: 23.6 LBS.

RAYCAP RSD-FMC-Z16MS-21NN
DISCONNECT

Peter J Tardy
12/18/2025
PETER J TARDY, PE
NEW JERSEY PROFESSIONAL ENGINEER
NJ LIC NO 41990

FPA
FRENCH & PARRELLO
ASSOCIATES
Corporate Office:
1800 Rt 34, Suite 101
Wall, New Jersey 07719
732.312.9600
FPAengineers.com
New Jersey • New York • Pennsylvania • Massachusetts

OWNER/DEVELOPER:
CROWN CASTLE
The Foundation for a Wireless World.

TITLE:
Crown Castle Fiber LLC
1288 STUART ROAD
PRINCETON, NJ
JURISDICTION: MUNICIPALITY OF PRINCETON

REV.	DATE	REVISION DESCRIPTION
2	02/21/24	REVISED PER COMMENTS
3	11/27/24	REVISED ANTENNA MODEL
4	09/10/25	REVISED POLE LOCATION
5	10/15/25	REVISED POLE LOCATION
6	12/18/25	ISSUED AS FINAL

DRAWN BY:	CHECKED BY:	APPROVED BY:
ARC	ARC	PJT

PROJECT NUMBER: 2438C.129.003

NODE ID: PCT-006

SCU #: 402142

DATE DRAWN: 11/02/2023

SHEET: 5 of 8

ITEM NO.	PART NUMBER	DESCRIPTION PART NAME	DIMENSIONS	MATERIAL	QTY	UNIT WT. LBS
1	TPB	Top Pole Bracket	Length 10" Width 4.60" Height 22"	Hot Rolled Steel, Galvanized	x1	11.25 lbs.
2	ITPB	Interlock Top Pole Bracket	Length 8.10" Width 3.90" Height 21.75"	Hot Rolled Steel, Galvanized	x1	9 lbs.
3	GSAE-10	Galvanized Steel Antenna Extension 8" Height	Height 8" Diameter 5" Flange 5.375"	Steel Tubing	x1	8 lbs.
4	SLAE	Self Leveling Antenna Extension	Length 6" Width 6" Height 5.25"	Hot Rolled Steel, Galvanized	x1	4 lbs.

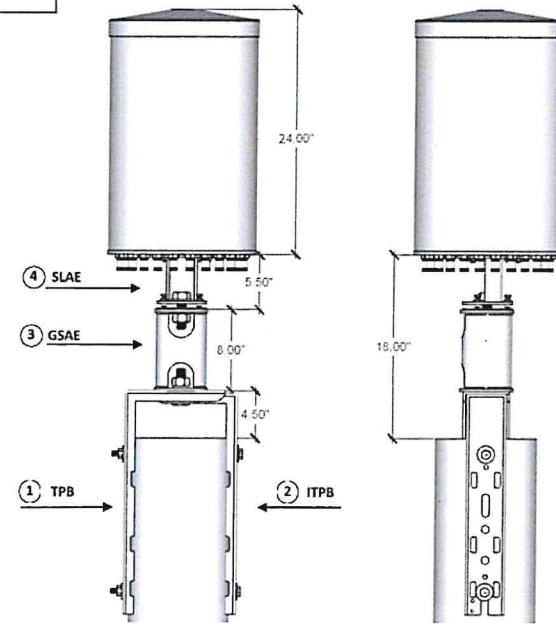
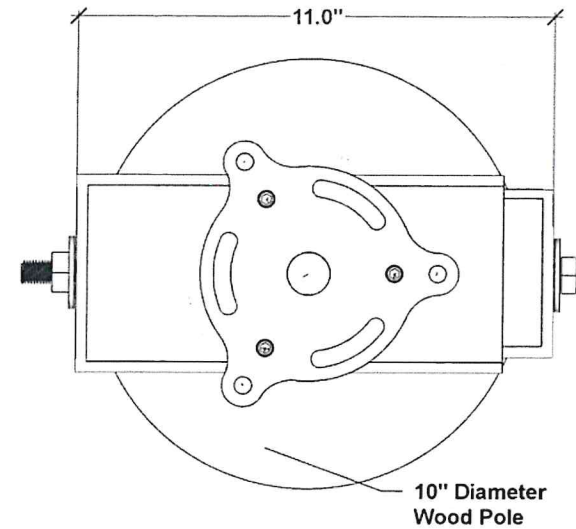

NYM MK-183
POLE TOP MOUNT

NYM
6 Cain Street Rochester, NY 14611
P: 585-254-9353 NYMFG.COM

PROPRIETARY AND CONFIDENTIAL
THE INFORMATION IN THIS DRAWING IS THE SOLE PROPERTY OF NEW YORK MANUFACTURING. ANY REPRODUCTION IN PART OR AS A WHOLE WITHOUT WRITTEN PERMISSION OF NEW YORK MANUFACTURING IS PROHIBITED

FILE: MK-183

COMMENTS:

DESCRIPTION:
Wood Pole Top

DRAWN BY: SAL ANSELMO DATE: 2/21/2023

REV	DESCRIPTION	DATE	BY

PAGE: 1 of 4

PART NUMBER:
MK-183-PT-PC8028

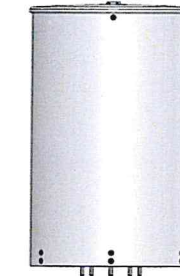

MECHANICAL SPECIFICATIONS:
HEIGHT: 24 IN.
DIAMETER: 14.6 IN.
WEIGHT: 26 LBS.

JMA WIRELESS
CYL2Q16R-2xy
ANTENNA



MECHANICAL SPECIFICATIONS:
HEIGHT: 19.73 IN.
WIDTH: 15.96 IN.
DEPTH: 10.04 IN.
WEIGHT: 84.4 LBS.

SAMSUNG
RADIO RFV01U-D1A B2 B66

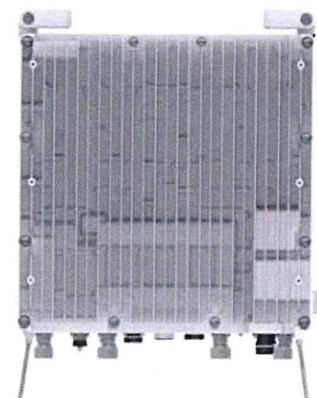

MECHANICAL SPECIFICATIONS:
HEIGHT: 19.73 IN.
WIDTH: 15.0 IN.
DEPTH: 8.1 IN.
WEIGHT: 70.3 LBS.

SAMSUNG
RADIO RFV01U-D2A B5 B13

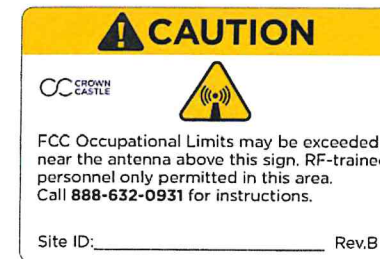

NOTES:

- SIGNAGE ATTACHED ON:
WOOD POLES = SIGN ON ALUMINUM WITH STAINLESS STEEL SCREWS.
METAL POLES = ADHESIVE VINYL OR PLACARD STRAPPED WITH STAINLESS STEEL TIES.
CONCRETE/COMPOSITE = PLACARD STRAPPED WITH STAINLESS STEEL TIES.
FIBERGLASS = PLACARD STRAPPED WITH STAINLESS STEEL TIES.
- AFFIX SIGN TO THE STRUCTURE AS PER EME REPORT.
- THE SIGN MUST BE COMPLETELY READABLE FROM OUTSIDE THE DANGER ZONE.

RF "YELLOW"
CAUTION SIGN

CROWN CASTLE CrownCastle.com

FOR LEASE INFORMATION: **877-486-9377**
FOR EMERGENCY 24 HOUR SERVICE: **888-632-0931**

SYSTEM NAME:
A LOC SCU:
Z LOC SCU:
SITE ADDRESS:

SITE ID SIGN

Peter J Tardy 12/18/2025
PETER J TARDY, PE
NEW JERSEY PROFESSIONAL ENGINEER NJ LIC NO 41990

ENGINEER:

FPA
FRENCH & PARRELLO ASSOCIATES
Corporate Office:
1800 Rt 34, Suite 101
Wall, New Jersey 07719
732.312.9800
FPAengineers.com
New Jersey • New York • Pennsylvania • Massachusetts

OWNER/DEVELOPER:

CROWN CASTLE
The Foundation for a Wireless World.

TITLE:
Crown Castle Fiber LLC
1288 STUART ROAD
PRINCETON, NJ
JURISDICTION: MUNICIPALITY OF PRINCETON

REV.	DATE	REVISION DESCRIPTION
2	02/21/24	REVISED PER COMMENTS
3	11/27/24	REVISED ANTENNA MODEL
4	09/10/25	REVISED POLE LOCATION
5	10/15/25	REVISED POLE LOCATION
6	12/18/25	ISSUED AS FINAL

DRAWN BY: ARC CHECKED BY: ARC APPROVED BY: PJT

PROJECT NUMBER: 2438C.129.003

NODE ID: PCT-006

SCU #: 402142

DATE DRAWN: 11/02/2023

SHEET: 6 of 8

Scenario Name:-
Scenario 107

Project:- Princeton
Cluster Name:- Philadelphia Market

Designed by:- Prashant Patel
Customer:- Verizon
Date Created:- 10/31/2023
Revision:- 1
Sheet:- 107



New Antenna

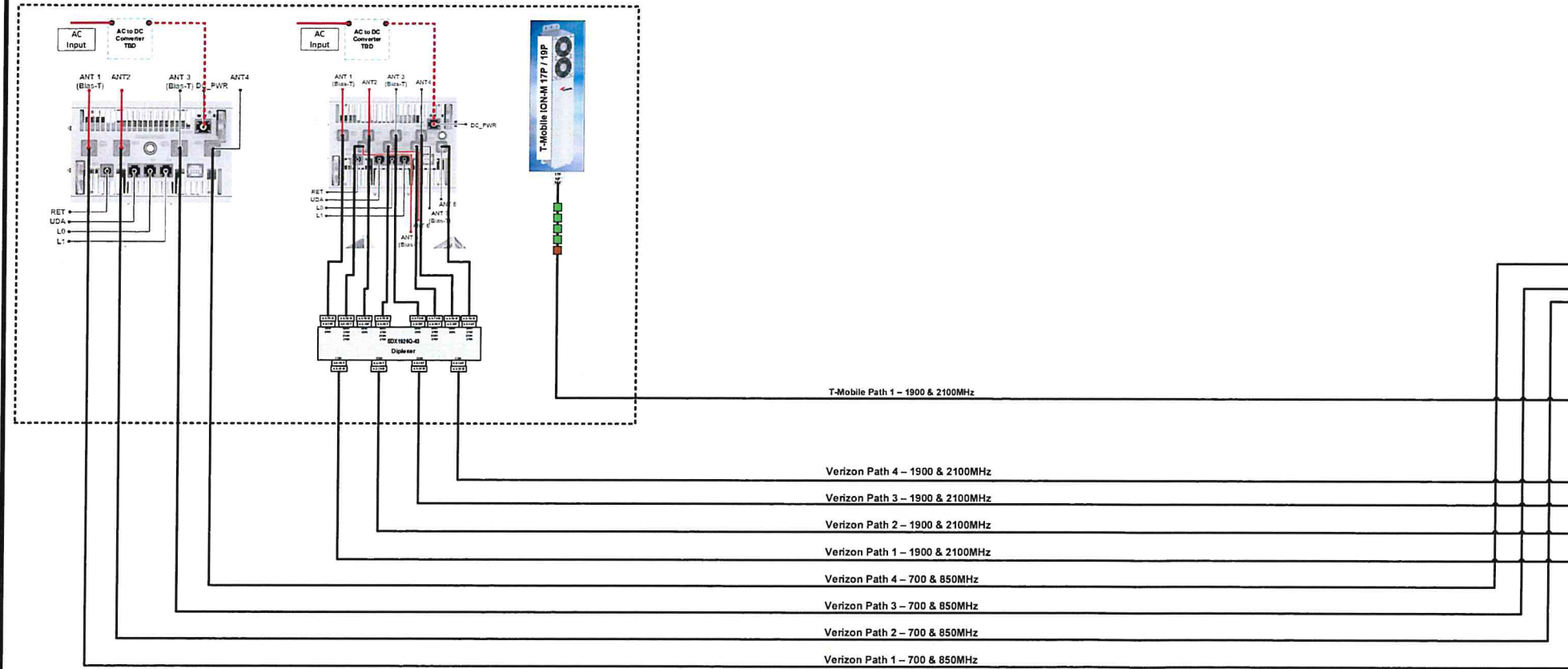
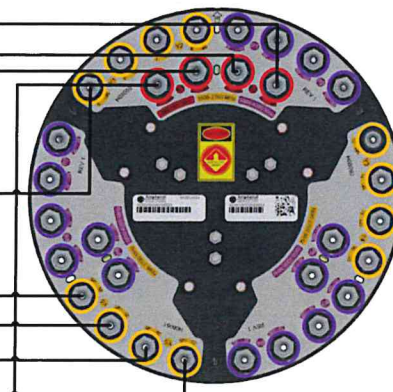

Carrier	Band (MHz)	Color	Description	Path 1	Path 2	Comments
Verizon	700	1x Red	Brown	Brown/Brown		Alternatively named Cellular Band
	850	2x Red	Brown	Brown/Brown		Alternatively named PCS Band
	1900	3x Red	Brown	Brown/Brown		Alternatively named AWS or 1700 Band
	2100	4x Red	Brown	Brown/Brown		Alternatively named AWS or 1700 Band
AT&T	700	1x Blue	Brown	Brown/Brown		Alternatively named Cellular Band
	850	2x Blue	Brown	Brown/Brown		Alternatively named PCS Band
	1900	3x Blue	Brown	Brown/Brown		Alternatively named AWS or 1700 Band
	2100	4x Blue	Brown	Brown/Brown		Alternatively named WCS Band
T-Mobile	700	1x Green	Brown	Brown/Brown		Alternatively named PCS Band
	1900	3x Green	Brown	Brown/Brown		Alternatively named AWS or 1700 Band
	2100	4x Green	Brown	Brown/Brown		Alternatively named AWS or 1700 Band
Metro	2100	4x Purple	Brown	Brown/Brown		Alternatively named AWS or 1700 Band
Sprint	700	1x Yellow	Brown	Brown/Brown		Alternatively named Cellular Band
	850	2x Yellow	Brown	Brown/Brown		Alternatively named PCS Band
	1900	3x Yellow	Brown	Brown/Brown		Alternatively named AWS or 1700 Band
	2100	4x Yellow	Brown	Brown/Brown		Alternatively named AWS or 1700 Band
	2300	5x Yellow	Brown	Brown/Brown		Alternatively named WCS Band
	2500	6x Yellow	Brown	Brown/Brown		Alternatively named WCS Band

FREQUENCY	ARRAY	CONNECTOR	CONNECTOR TYPE	FREQUENCY	ARRAY	CONNECTOR	CONNECTOR TYPE
3300-4200 MHz	P1	17-18	(2x) 4.3-10 Female	696-960 MHz	R1	1-2	(2x) 4.3-10 Female
3300-4200 MHz	P2	19-20	(2x) 4.3-10 Female	696-960 MHz	R2	3-4	(2x) 4.3-10 Female
3300-4200 MHz	P3	21-22	(2x) 4.3-10 Female	1695-2700 MHz	Y1	5-6	(2x) 4.3-10 Female
3300-4200 MHz	P4	23-24	(2x) 4.3-10 Female	1695-2700 MHz	Y2	7-8	(2x) 4.3-10 Female
3300-4200 MHz	P5	25-26	(2x) 4.3-10 Female	1695-2700 MHz	Y3	9-10	(2x) 4.3-10 Female
3300-4200 MHz	P6	27-28	(2x) 4.3-10 Female	1695-2700 MHz	Y4	11-12	(2x) 4.3-10 Female
3300-4200 MHz	P7	29-30	(2x) 4.3-10 Female	1695-2700 MHz	Y5	13-14	(2x) 4.3-10 Female
3300-4200 MHz	P8	31-32	(2x) 4.3-10 Female	1695-2700 MHz	Y6	15-16	(2x) 4.3-10 Female

Peter J Tardy
PETER J TARDY, PE
NEW JERSEY PROFESSIONAL ENGINEER
DATE: 12/18/2025
NJ LIC NO. 41990

FPA
FRENCH & PARRELLO ASSOCIATES
Corporate Office: 1800 RI 34, Suite 101 Wall, New Jersey 07719 732.312.9800
FPAengineers.com
New Jersey • New York • Pennsylvania • Massachusetts

OWNER/DEVELOPER:
CROWN CASTLE
The Foundation for a Wireless World.

TITLE:
Crown Castle Fiber LLC
1288 STUART ROAD
PRINCETON, NJ
JURISDICTION: MUNICIPALITY OF PRINCETON

REVISIONS

REV.	DATE	REVISION DESCRIPTION
2	02/21/24	REVISED PER COMMENTS
3	11/27/24	REVISED ANTENNA MODEL
4	09/10/25	REVISED POLE LOCATION
5	10/15/25	REVISED POLE LOCATION
6	12/18/25	ISSUED AS FINAL

DRAWN BY: ARC
CHECKED BY: ARC
APPROVED BY: PJT

PROJECT NUMBER: 2438C.129.003
NODE ID: PCT-006
SCU #: 402142
DATE DRAWN: 11/02/2023
SHEET: 7 of 8

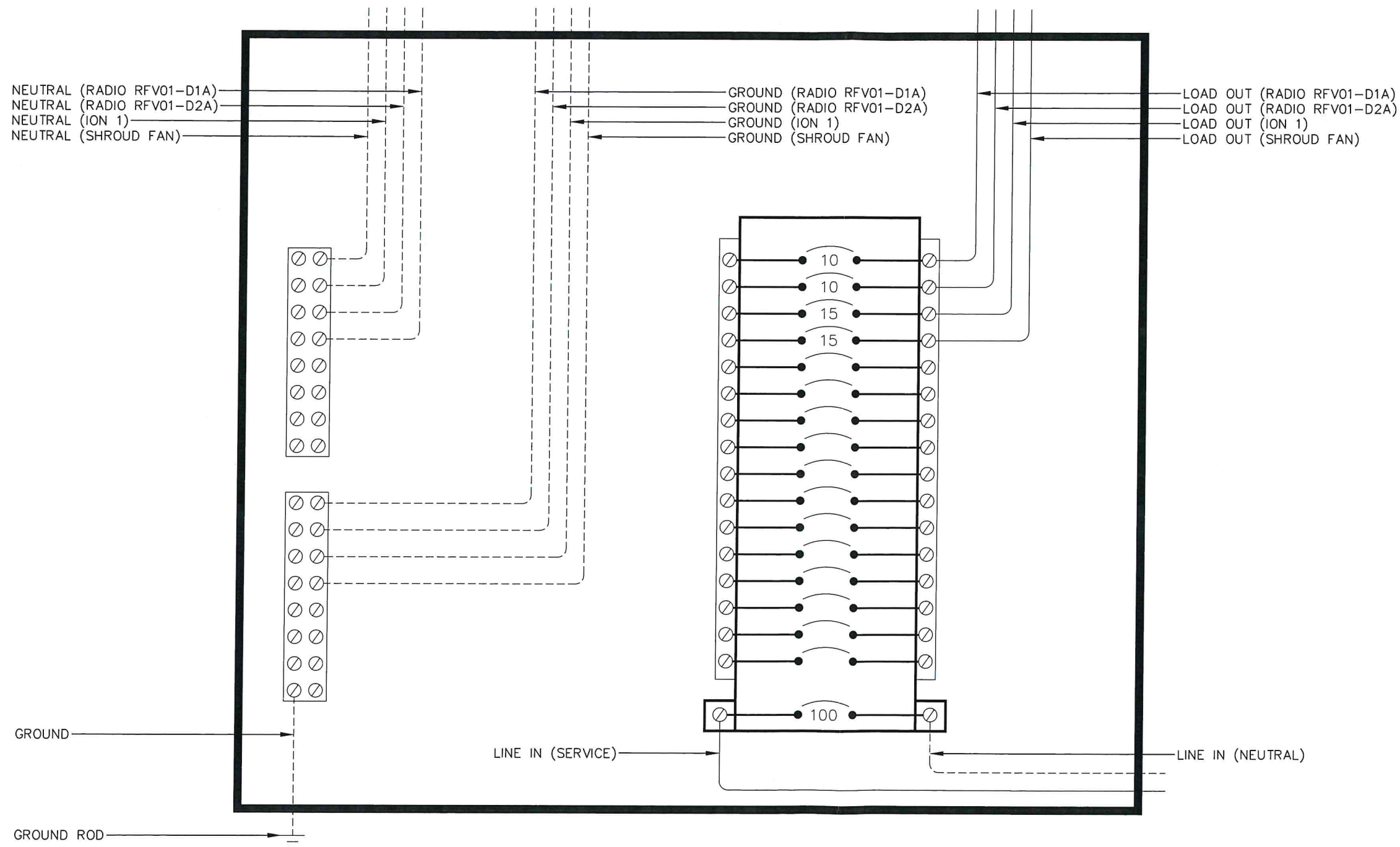

Peter J Tardy

12/18/2025

PETER J TARDY, PE
NEW JERSEY PROFESSIONAL ENGINEER NJ LIC NO 41990

ENGINEER:



Corporate Office:
1800 Rt 34, Suite 101
Wall, New Jersey 07719
732.312.9800

FPAengineers.com

New Jersey New York Pennsylvania Massachusetts

OWNER/DEVELOPER:



TITLE:
Crown Castle Fiber LLC
1288 STUART ROAD
PRINCETON, NJ
JURISDICTION: MUNICIPALITY OF PRINCETON

REVISIONS

REV.	DATE	REVISION DESCRIPTION
2	02/21/24	REVISED PER COMMENTS
3	11/27/24	REVISED ANTENNA MODEL
4	09/10/25	REVISED POLE LOCATION
5	10/15/25	REVISED POLE LOCATION
6	12/18/25	ISSUED AS FINAL

DRAWN BY:	CHECKED BY:	APPROVED BY:
ARC	ARC	PJT

PROJECT NUMBER: 2438C.129.003

NODE ID: PCT-006

SCU #: 402142

DATE DRAWN: 11/02/2023

SHEET: 8 OF 8

SITE LICENSE AGREEMENT
1267 Great Road

This Site License Agreement is made this _____ day of _____, 2026 by and between the MUNICIPALITY OF PRINCETON (“Licensor”) and CROWN CASTLE Fiber LLC, a Delaware Limited Liability Company (“Licensee”).

1. Rights of Way Use Agreement. As referenced in Exhibit 2 of a certain Rights of Way Use Agreement between Licensor and Licensee ("Agreement"), Licensee has submitted a Site License Application pursuant to the Agreement, and Licensor has reviewed the application and grants approval subject to the terms of this Site License Agreement. All of the terms and conditions of the Agreement are incorporated hereby by reference and made a part hereof without the necessity of repeating or attaching the Agreement. In the event of a contradiction or inconsistency between the terms of the Agreement and this Site License Agreement, the terms of this Site License Agreement shall govern. Capitalized terms used in this Site License Agreement shall have the same meaning ascribed to them in the Agreement unless otherwise indicated herein.
2. Project Description and Locations. Licensee shall have the right to install and attach Wireless Installations on, under, and above the public right of way owned or controlled by Licensor, on, in and adjacent to the specific Structure and Infrastructure as identified and described in Exhibit 1 attached hereto (collectively the "Licensed Site").
3. Term. The Site License Term of this Site License Agreement shall be as set forth in Section 2 of the Agreement.
4. Fee. The Fee shall be in the amount and otherwise payable in accordance with the Agreement as set forth in Section 4 of the Agreement.
5. Special Provisions, If Any (Specific to the Licensed Site).

[SIGNATURES APPEAR ON FOLLOWING PAGE]

LICENSOR:

MUNICIPALITY OF PRINCETON

By: _____

Print Name:

Title:

Date: _____

LICENSEE:

Crown Castle Fiber LLC
a New York Limited Liability Company

By: _____

Print Name:

Title:

Date: _____

EXHIBITS: Licensed Site, Wireless Installation Equipment List and Plans

EXHIBIT 1 TO SITE LICENSE AGREEMENT

Licensed Site, Wireless Installation Equipment List and Plans

Licensee Wireless Installation Reference: **PCT-015**

SCU: **410666**

Site Name: **1267 Great Road**

FA / USID:

PTN / PACE:

Structure pole number: **NT**

Structure Latitude and Longitude (Approximate): **40.38067, -74.69774**

Wireless Installation Equipment List: Please see attached construction drawings referenced below:

Crown Castle Fiber LLC | 1267 Great Road | Jurisdiction: Municipality of Princeton | Proposed Small Cell Site dated
05/08/2025 last revised 09/02/2025



INDEX TO SHEETS	
DWG #	DRAWING TITLE
1	COVER SHEET
2	PROPOSED POLE CONFIGURATION
3	PROPOSED POLE LOCATION PHOTOS (N&S)
4	PROPOSED POLE LOCATION PHOTOS (E&W)
5	PROPOSED EQUIPMENT DETAILS
6	PROPOSED ANTENNA DETAILS
7	PROPOSED RADIO & SITE DETAILS
8	WIRING DIAGRAM
9	DISCONNECT BOX

PROPOSED POLE CLASS: 2

Crown Castle Fiber LLC
1267 GREAT ROAD
JURISDICTION: MUNICIPALITY OF PRINCETON
PROPOSED SMALL CELL INSTALLATION

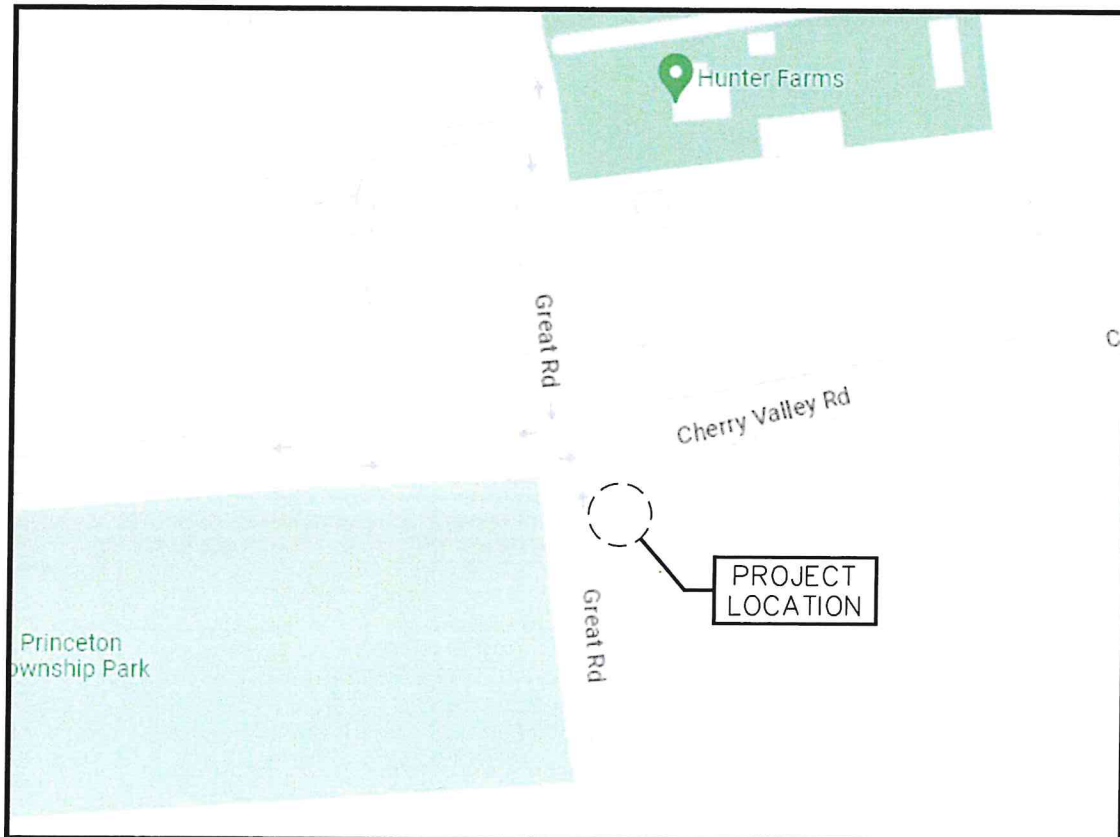
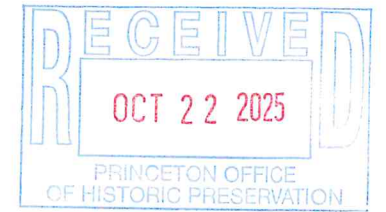

NOT TO SCALE

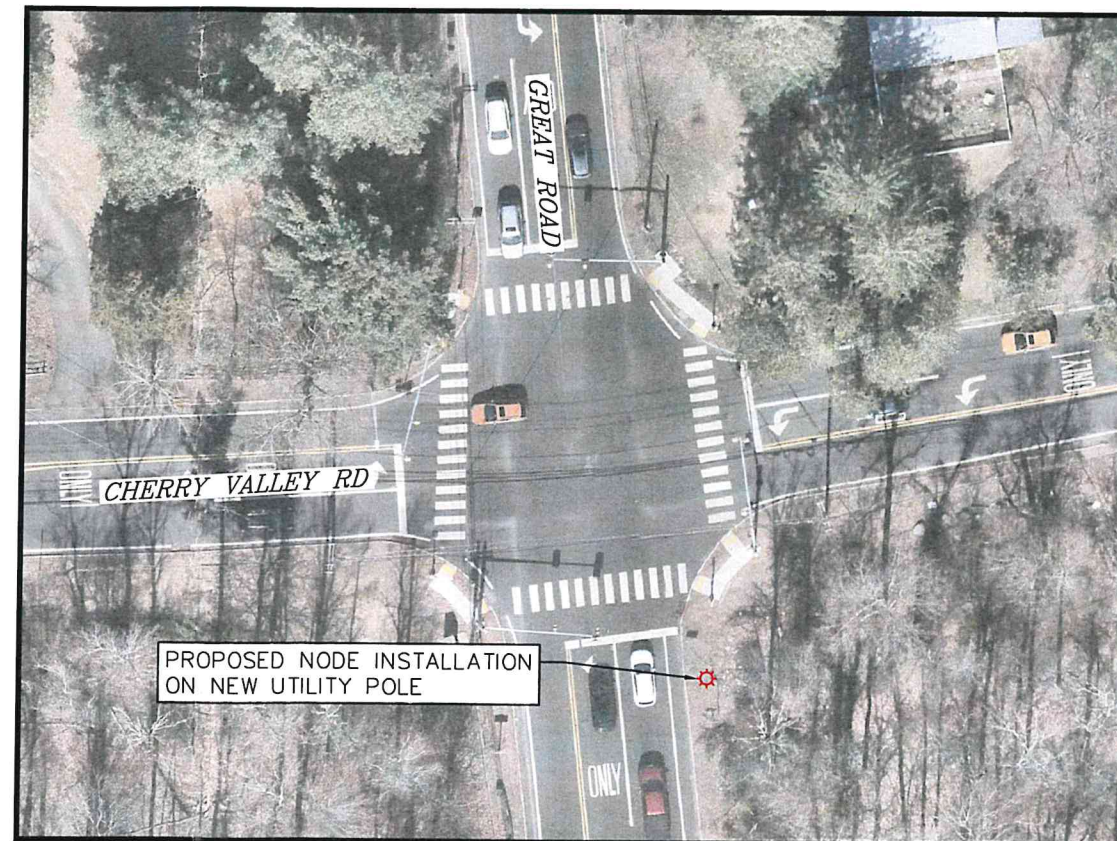

NOT TO SCALE

LOCATION MAP

LATITUDE: 40.38067°N
LONGITUDE: -74.69774°W
BLOCK: 401, LOT: 1

NODE PLACEMENT

1267 GREAT ROAD
PROPOSED CROWN CASTLE WOOD POLE
ON THE SOUTHEAST CORNER OF
CHERRY VALLEY RD AND GREAT RD
POLE ID: TBD



Know what's below.
Call before you dig.

Peter J. Tardy 09/02/2025 DATE
PETER J. TARDY, PE NEW JERSEY PROFESSIONAL ENGINEER LIC NO 41990

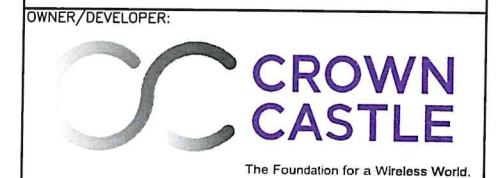

TITLE:
CROWN CASTLE FIBER LLC
1267 GREAT ROAD
PRINCETON, NJ
JURISDICTION: MUNICIPALITY OF PRINCETON

REVISIONS		
REV.	DATE	REVISION DESCRIPTION
0	05/08/25	ISSUED FOR REVIEW
1	06/04/25	REVISED POLE HEIGHT
2	06/26/25	ISSUED AS FINAL
3	09/02/25	REVISED PER COMMENTS

DRAWN BY:	CHECKED BY:	APPROVED BY:
ARC	ARC	PJT

PROJECT NUMBER:	2438C.212
NODE ID:	PCT-015
SCU # / CASCADE ID:	410666/5000884478
DATE DRAWN:	05/08/25

SHEET:
1 of 9

NOTES:
1. POINT OF CONTACT FOR POWER AND TELCO TO BE DETERMINED PENDING UTILITY COORDINATION.
2. PROPOSED SECONDARY AND FIBER LOCATION AND HEIGHT TBD PENDING UTILITY COORDINATION.

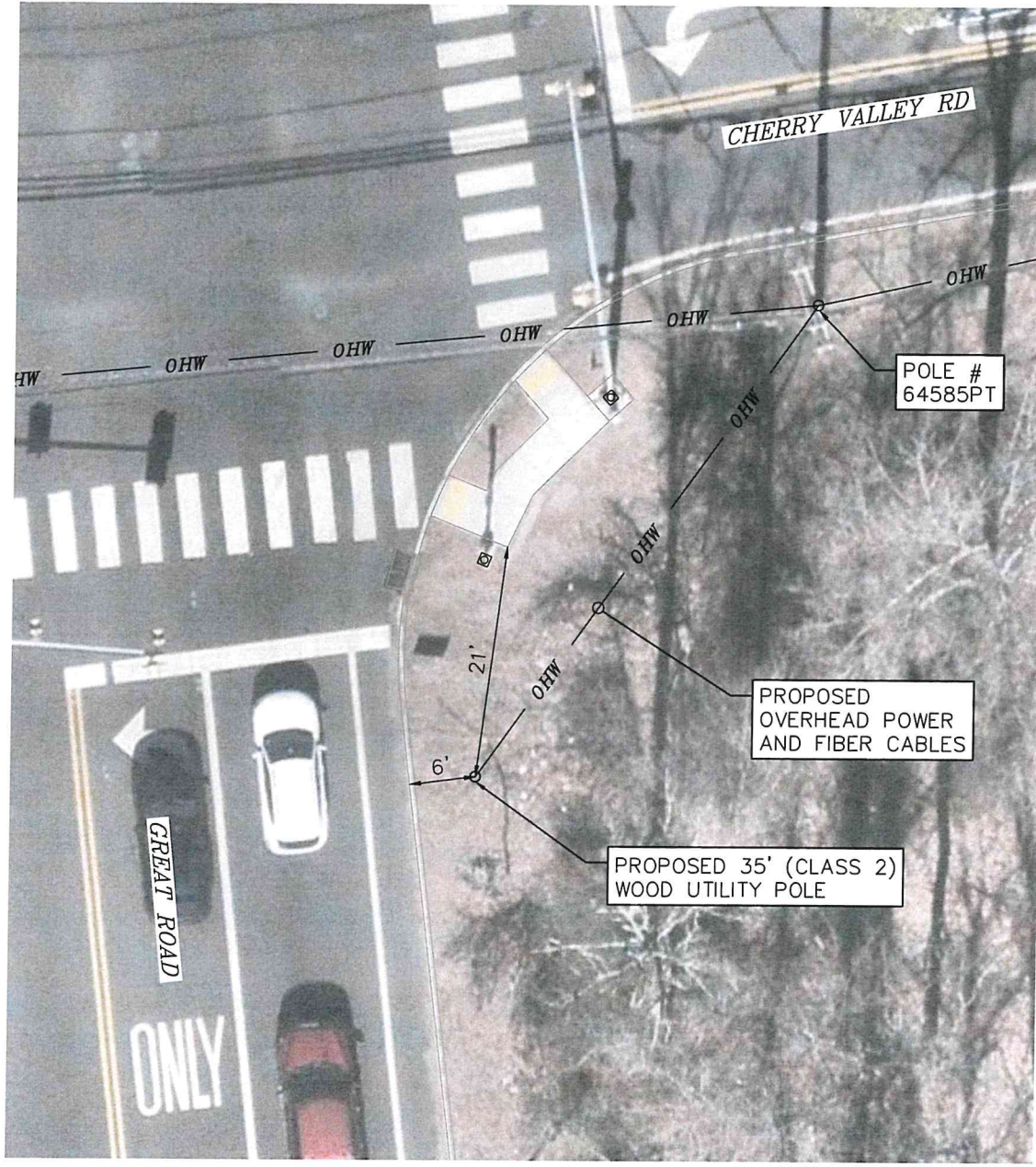

PROPOSED POLE LOCATION

NOT TO SCALE

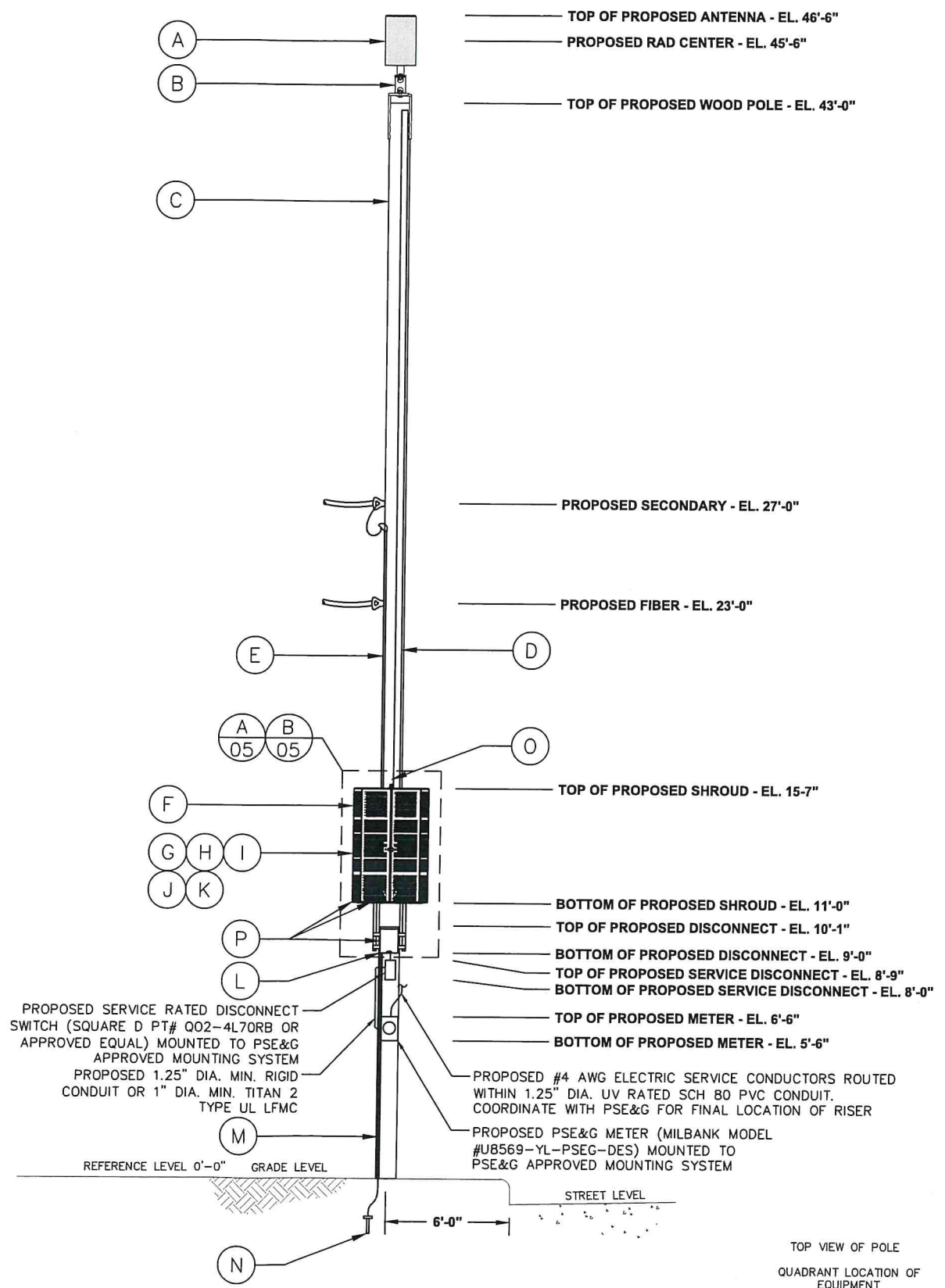

PROPOSED POLE DETAIL
LOOKING SOUTH

- A. PROPOSED ANTENNA:
(1) AMPHENOL 2C6U2VT360X06F040s4
24.0"x14.6" (HxW) - 28.0 LBS
- B. PROPOSED POLE TOP MOUNT:
(1) NYA MK-183
TO BE THRU-BOLTED TO POLE
MOUNT COLOR: BROWN
- C. PROPOSED POLE:
INSTALL NEW 50' CLASS 2 WOOD POLE
HEIGHT = 43'-0" (AGL)
- D. INSTALL 4" PVC RISER U-GUARD:
PROPOSED #4 AWG GROUND WIRE AND COAX/FIBER CABLES
TO BE ROUTED WITHIN
- E. INSTALL 1.25" PVC SCH. 80 POWER RISER CONDUIT FROM
DISCONNECT TO SECONDARY
- F. INSTALL SHROUD CABINET:
RAYCAP RAES-225408-B
55.0"x36.0"x20.0" (HxWxD) - 550 LBS
EQUIPMENT COLOR: BROWN
TO BE THRU-BOLTED TO POLE
- G. INSTALL RADIO UNIT WITHIN NEW SHROUD CABINET:
(1) SAMSUNG RADIO RFV01U-D1A B2 B66
19.73"x15.96"x10.04" (HxWxD) - 84.4 LBS
- H. INSTALL RADIO UNIT WITHIN NEW SHROUD CABINET:
(1) SAMSUNG RADIO RFV01U-D2A B5 B13
19.73"x15.0"x8.1" (HxWxD) - 70.3 LBS
- I. INSTALL DIPLEXER WITHIN NEW SHROUD CABINET:
(1) COMMSCOPE SDX19280-43
4.17"x6.93"x2.91" (HxWxD) - 6.17 LBS
- J. INSTALL DIPLEXER WITHIN NEW SHROUD CABINET:
(4) COMMSCOPE CRC78-DS-43
6.38"x6.93"x2.89" (HxWxD) - 3.95 LBS
- K. INSTALL RECTIFIER WITHIN NEW SHROUD CABINET:
(2) DELTA ESR-48/38A U-5
15.5"x11.3"x3.7" (HxWxD) - 21.0 LBS
- L. INSTALL 100A LOAD CENTER:
(1) SQUARE D Q0612L100TRB
12.44"x8.9"x4.02" (HxWxD) - 9.26 LBS
EQUIPMENT COLOR: BROWN
TO BE MOUNTED BELOW EQUIPMENT SHROUD
- M. INSTALL 1" PVC U-GUARD:
PROPOSED #4 AWG GROUND WIRE ROUTED WITHIN
- N. INSTALL 8' GROUND ROD
- O. INSTALL (2) "YELLOW" CAUTION SIGNS ABOVE EQUIPMENT
SHROUD ON EITHER SIDE OF POLE
- P. INSTALL SITE ID SIGN ON BOTTOM LEFT CORNER OF EQUIPMENT
SHROUD AND INSIDE DOOR OF DISCONNECT

Peter J. Tardy
09/02/2025
DATE
PETER J. TARDY, PE
NEW JERSEY PROFESSIONAL ENGINEER
LIC NO 41990

ENGINEER:
FPA
FRENCH & PARRELLO
ASSOCIATES
Camden Office:
2 Riverside Drive, Suite 503
Camden, New Jersey 08101
609.862.1582
FPAengineers.com
New Jersey • New York • Pennsylvania • Massachusetts

OWNER/DEVELOPER:
CROWN CASTLE
The Foundation for a Wireless World.

TITLE:
CROWN CASTLE FIBER LLC
1267 GREAT ROAD
PRINCETON, NJ
JURISDICTION: MUNICIPALITY OF PRINCETON

REV.	DATE	REVISION DESCRIPTION
0	05/08/25	ISSUED FOR REVIEW
1	06/04/25	REVISED POLE HEIGHT
2	06/26/25	ISSUED AS FINAL
3	09/02/25	REVISED PER COMMENTS

DRAWN BY:	CHECKED BY:	APPROVED BY:
ARC	ARC	PJT

PROJECT NUMBER:	2438C.212
NODE ID:	PCT-015
SCU # / CASCADE ID:	410666/5000884478
DATE DRAWN:	05/08/25

SHEET:
2 of 9



PROPOSED POLE LOCATION PHOTO
LOOKING NORTH



PROPOSED POLE LOCATION PHOTO
LOOKING SOUTH

Peter J. Tardy 09/02/2025
DATE
PETER J. TARDY, PE
NEW JERSEY PROFESSIONAL ENGINEER LIC NO 41990

ENGINEER:
FPA
FRENCH & PARRELLO
ASSOCIATES
Camden Office:
2 Riverside Drive, Suite 503
Camden, New Jersey 08101
609.862.1582
FPAengineers.com
New Jersey New York Pennsylvania Massachusetts

OWNER/DEVELOPER:
CC CROWN CASTLE
The Foundation for a Wireless World.

TITLE:
CROWN CASTLE FIBER LLC
1267 GREAT ROAD
PRINCETON, NJ
JURISDICTION: MUNICIPALITY OF PRINCETON

REVISIONS		
REV.	DATE	REVISION DESCRIPTION
0	05/08/25	ISSUED FOR REVIEW
1	06/04/25	REVISED POLE HEIGHT
2	06/26/25	ISSUED AS FINAL
3	09/02/25	REVISED PER COMMENTS

DRAWN BY:	CHECKED BY:	APPROVED BY:
ARC	ARC	PJT

PROJECT NUMBER:	2438C.212
NODE ID:	PCT-015
SCU # / CASCADE ID:	410666/5000884478
DATE DRAWN:	05/08/25
SHEET:	3 of 9



PROPOSED POLE LOCATION PHOTO
LOOKING EAST



PROPOSED POLE LOCATION PHOTO
LOOKING WEST

Peter J. Tardy 09/02/2025
 PETER J. TARDY, PE DATE
 NEW JERSEY PROFESSIONAL ENGINEER LIC NO 41990
 ENGINEER:
FPA Camden Office:
 FRENCH & PARRELLO 2 Riverside Drive, Suite 503
 ASSOCIATES Camden, New Jersey 08101
 FPAengineers.com 609.662.1582
 New Jersey • New York • Pennsylvania • Massachusetts

OWNER/DEVELOPER:
 **CROWN CASTLE**
 The Foundation for a Wireless World.

TITLE:
 CROWN CASTLE FIBER LLC
 1267 GREAT ROAD
 PRINCETON, NJ
 JURISDICTION: MUNICIPALITY OF PRINCETON

REVISIONS		
REV.	DATE	REVISION DESCRIPTION
0	05/08/25	ISSUED FOR REVIEW
1	06/04/25	REVISED POLE HEIGHT
2	06/26/25	ISSUED AS FINAL
3	09/02/25	REVISED PER COMMENTS

DRAWN BY:	CHECKED BY:	APPROVED BY:
ARC	ARC	PJT

PROJECT NUMBER:	2438C.212
NODE ID:	PCT-015
SCU # / CASCADE ID:	410666/5000884478
DATE DRAWN:	05/08/25
SHEET:	4 of 9

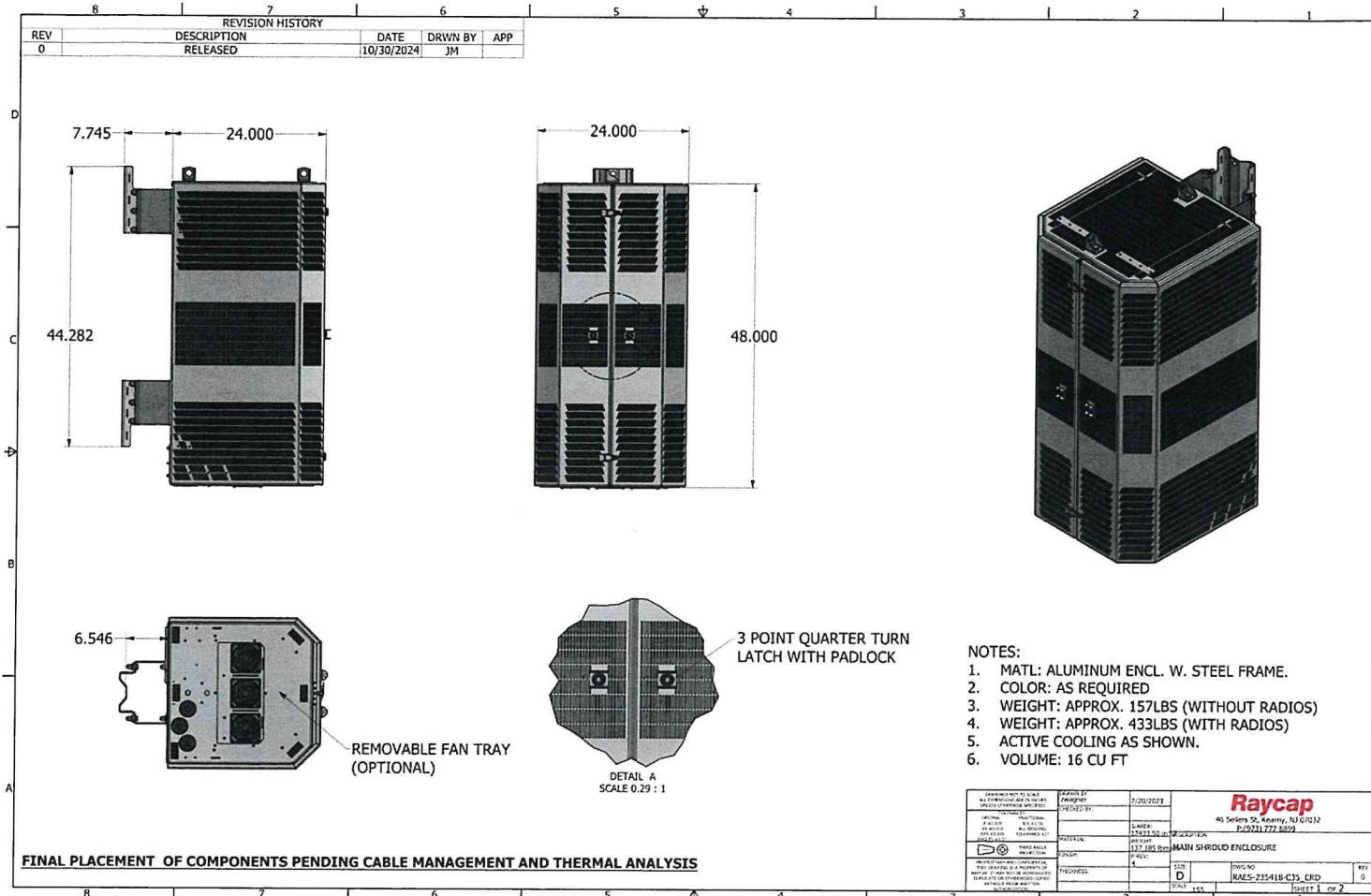

DETAIL A
RAYCAP RAES-235418-C35
SHROUD

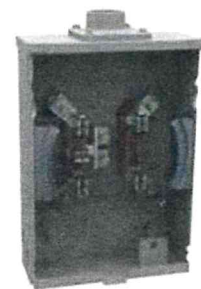

MECHANICAL SPECIFICATIONS:
HEIGHT: 11.5 IN.
WIDTH: 8.0 IN.
DEPTH: 3.3 IN.

MILBANK U8569-yl-pseg-des
METER PAN



MECHANICAL SPECIFICATIONS:
HEIGHT: 9.37 IN.
WIDTH: 4.88 IN.
WEIGHT: 5.05 LBS.

SQUARE D Q02-4L70RB
DISCONNECT



MECHANICAL SPECIFICATIONS:
HEIGHT: 12.44 IN.
WIDTH: 8.90 IN.
DEPTH: 4.02 IN.
WEIGHT: 9.26 LBS.

SQUARE D Q0612L100TRB
LOAD CENTER

Peter J. Tardy 09/02/2025
DATE
PETER J. TARDY, PE
NEW JERSEY PROFESSIONAL ENGINEER LIC NO 41990

ENGINEER:

Camden Office:
2 Riverside Drive, Suite 503
Camden, New Jersey 08101
609.862.1582
FPAengineers.com
New Jersey • New York • Pennsylvania • Massachusetts

OWNER/DEVELOPER:

CROWN CASTLE
The Foundation for a Wireless World.

TITLE:
CROWN CASTLE FIBER LLC
1267 GREAT ROAD
PRINCETON, NJ
JURISDICTION: MUNICIPALITY OF PRINCETON

REVISIONS		
REV.	DATE	REVISION DESCRIPTION
0	05/08/25	ISSUED FOR REVIEW
1	06/04/25	REVISED POLE HEIGHT
2	06/26/25	ISSUED AS FINAL
3	09/02/25	REVISED PER COMMENTS

DRAWN BY:	CHECKED BY:	APPROVED BY:
ARC	ARC	PJT

PROJECT NUMBER:	2438C.212
NODE ID:	PCT-015
SCU # / CASCADE ID:	410666/5000884478
DATE DRAWN:	05/08/25
SHEET:	5 of 9

ITEM NO.	PART NUMBER	DESCRIPTION PART NAME	DIMENSIONS	MATERIAL	QTY	UNIT WT. LBS.
1	TPB	Top Pole Bracket	Length 10" Width 4.60" Height 22"	Hot Rolled Steel, Galvanized	x1	11.25 lbs.
2	ITPB	Interlock Top Pole Bracket	Length 8.10" Width 3.90" Height 21.75"	Hot Rolled Steel, Galvanized	x1	9 lbs.
3	GSAE-10	Galvanized Steel Antenna Extension 8" Height	Height 8" Diameter 5" Flange 5.375"	Steel Tubing	x1	8 lbs.
4	SLAE	Self Leveling Antenna Extension	Length 6" Width 6" Height 5.25"	Hot Rolled Steel, Galvanized	x1	4 lbs.

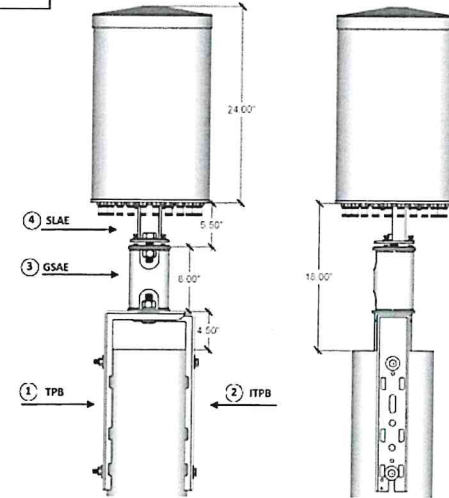
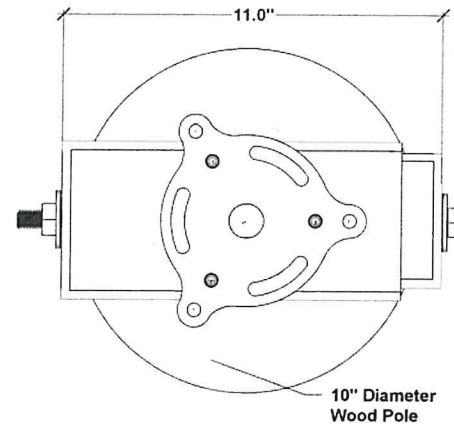

NYM MK-183
POLE TOP MOUNT

NYM

6 Calm Street Rochester, NY 14611
P: 585-254-9353 NYMFG.COM

PROPRIETARY AND CONFIDENTIAL
THE INFORMATION IN THIS DRAWING IS THE SOLE PROPERTY OF NEW YORK MANUFACTURING. ANY REPRODUCTION IN PART OR AS A WHOLE WITHOUT WRITTEN PERMISSION OF NEW YORK MANUFACTURING IS PROHIBITED.

FILE: MK-183

COMMENTS:

DESCRIPTION:
Wood Pole Top

DRAWN BY: SAL ANSELMO DATE: 2/21/2023

REV	DESCRIPTION	DATE	BY

PAGE: 1 of 4

PART NUMBER:
MK-183-PT-PC8028



MECHANICAL SPECIFICATIONS:
HEIGHT: 24 IN.
DIAMETER: 14.6 IN.
WEIGHT: 28.0 LBS.

AMPHENOL
2C6U2VT360X06F040s4
ANTENNA

Peter J. Tardy 09/02/2025
DATE

PETER J. TARDY, PE
NEW JERSEY PROFESSIONAL ENGINEER LIC NO 41990

ENGINEER:

FPA
FRENCH & PARRELLO
ASSOCIATES

Camden Office:
2 Riverside Drive, Suite 503
Camden, New Jersey 08101
609.862.1582
FPAengineers.com

New Jersey • New York • Pennsylvania • Massachusetts

OWNER/DEVELOPER:

CC CROWN CASTLE
The Foundation for a Wireless World.

TITLE:
CROWN CASTLE FIBER LLC
1267 GREAT ROAD
PRINCETON, NJ
JURISDICTION: MUNICIPALITY OF PRINCETON

REVISIONS		
REV.	DATE	REVISION DESCRIPTION
0	05/08/25	ISSUED FOR REVIEW
1	06/04/25	REVISED POLE HEIGHT
2	08/26/25	ISSUED AS FINAL
3	09/02/25	REVISED PER COMMENTS

DRAWN BY:	CHECKED BY:	APPROVED BY:
ARC	ARC	PJT

PROJECT NUMBER:	2438C.212
NODE ID:	PCT-015
SCU # / CASCADE ID:	410666/5000884478
DATE DRAWN:	05/08/25

COPYRIGHT © 2025, FRENCH & PARRELLO ASSOCIATES - THE COPYING OR REUSE OF THIS DOCUMENT, OR PORTIONS THEREOF, WITHOUT THE WRITTEN PERMISSION OF FRENCH & PARRELLO ASSOCIATES, PA IS PROHIBITED. DUE TO INHERENT ERRORS IN REPRODUCTION METHODS, ERRORS MAY OCCUR WHEN SCALING THIS DRAWING.

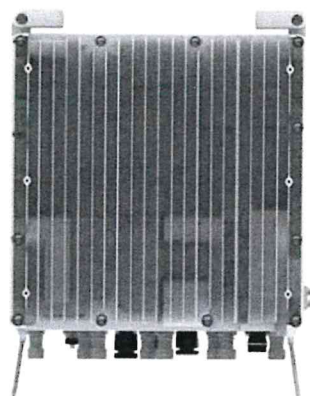

MECHANICAL SPECIFICATIONS:
HEIGHT: 19.73 IN.
WIDTH: 15.96 IN.
DEPTH: 10.04 IN.
WEIGHT: 84.4 LBS.

SAMSUNG
RADIO RFV01U-D1A B2 B66

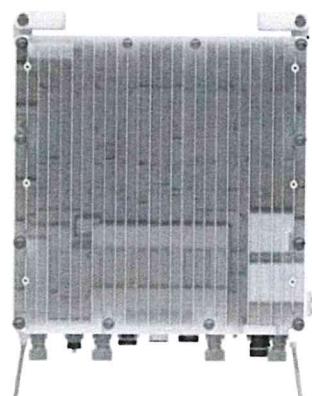

MECHANICAL SPECIFICATIONS:
HEIGHT: 19.73 IN.
WIDTH: 15.0 IN.
DEPTH: 8.1 IN.
WEIGHT: 70.3 LBS.

SAMSUNG
RADIO RFV01U-D2A B5 B13

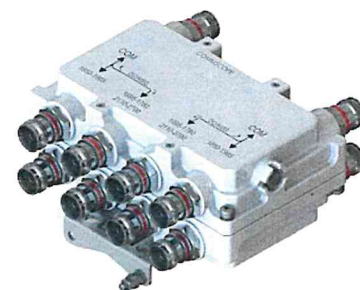

MECHANICAL SPECIFICATIONS:
HEIGHT: 4.17 IN.
WIDTH: 6.93 IN.
DEPTH: 2.91 IN.
WEIGHT: 6.17 LBS.

COMMSCOPE
DIPLEXER SDX1926Q-43



MECHANICAL SPECIFICATIONS:
HEIGHT: 15.5 IN.
WIDTH: 11.3 IN.
DEPTH: 3.7 IN.
WEIGHT: 21.0 LBS.

DELTA
RECTIFIER ESR-48/38A U-S



NOTES:

- SIGNAGE ATTACHED ON:
WOOD POLES = SIGN ON ALUMINUM WITH STAINLESS STEEL SCREWS.
METAL POLES = ADHESIVE VINYL OR PLACARD STRAPPED WITH STAINLESS STEEL TIES.
CONCRETE/COMPOSITE = PLACARD STRAPPED WITH STAINLESS STEEL TIES.
FIBERGLASS = PLACARD STRAPPED WITH STAINLESS STEEL TIES.
- AFFIX SIGN TO THE STRUCTURE AS PER EME REPORT.
- THE SIGN MUST BE COMPLETELY READABLE FROM OUTSIDE THE DANGER ZONE.

RF "YELLOW"
CAUTION SIGN



SITE ID SIGN

Peter J. Tardy 09/02/2025 DATE
PETER J. TARDY, PE NEW JERSEY PROFESSIONAL ENGINEER LIC NO 41990



TITLE:
CROWN CASTLE FIBER LLC
1267 GREAT ROAD
PRINCETON, NJ
JURISDICTION: MUNICIPALITY OF PRINCETON

REVISIONS		
REV.	DATE	REVISION DESCRIPTION
0	05/08/25	ISSUED FOR REVIEW
1	06/04/25	REVISED POLE HEIGHT
2	06/28/25	ISSUED AS FINAL
3	09/02/25	REVISED PER COMMENTS

DRAWN BY:	CHECKED BY:	APPROVED BY:
ARC	ARC	PJT

PROJECT NUMBER:	2438C.212
NODE ID:	PCT-015
SCU # / CASCADE ID:	410666/5000884478
DATE DRAWN:	05/08/25

SHEET:
7 of 9

Scenario Name:-
Scenario 109

Project:- Princeton
Date Created:- 10/31/2023
Cluster Name:- Philadelphia Market

Designed by:- Prashant Patel
Customer:- Verizon
Revision:- 1
Sheet:- 109

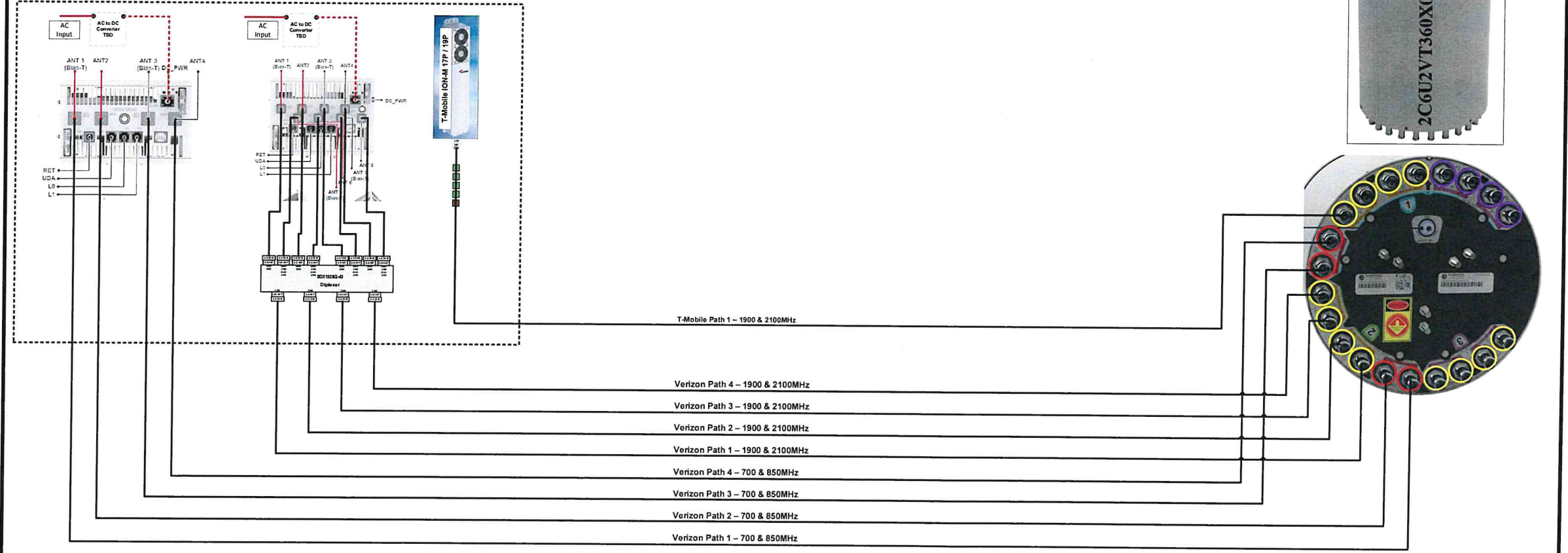

Carrier	Band (MHz)	Color	Description	Path 1	Path 2	Comments
Verizon	700	1x Red	Brown	Brown/Brown	Alternately named Cellular Band	
	850	2x Red	Brown	Brown/Brown	Alternately named PCS Band	
	1500	3x Red	Brown	Brown/Brown	Alternately named AWS or 1700 Band	
	2100	4x Red	Brown	Brown/Brown	Alternately named AWS or 1700 Band	
AT&T	700	1x Blue	Brown	Brown/Brown	Alternately named Cellular Band	
	850	2x Blue	Brown	Brown/Brown	Alternately named PCS Band	
	1900	3x Blue	Brown	Brown/Brown	Alternately named AWS or 1700 Band	
	2100	4x Blue	Brown	Brown/Brown	Alternately named WCS Band	
T-Mobile	700	1x Green	Brown	Brown/Brown	Alternately named Cellular Band	
	1900	3x Green	Brown	Brown/Brown	Alternately named PCS Band	
	2100	4x Green	Brown	Brown/Brown	Alternately named AWS or 1700 Band	
Metro	2100	4x Purple	Brown	Brown/Brown	Alternately named AWS or 1700 Band	
Sprint	700	1x Yellow	Brown	Brown/Brown	Alternately named Cellular Band	
	850	2x Yellow	Brown	Brown/Brown	Alternately named PCS Band	
	1500	3x Yellow	Brown	Brown/Brown	Alternately named AWS or 1700 Band	
	2100	4x Yellow	Brown	Brown/Brown	Alternately named WCS Band	
	2500	6x Yellow	Brown	Brown/Brown	Alternately named WCS Band	

ARRAY LAYOUT Topology				ARRAY LAYOUT Topology			
FREQUENCY	ARRAY	CONNECTOR	CONNECTOR TYPE	FREQUENCY	ARRAY	CONNECTOR	CONNECTOR TYPE
696-960 MHz	R1	1-2	(2x) 4.3-10 Female	1695-2700 MHz	Y4	11-12	(2x) 4.3-10 Female
696-960 MHz	R1	3-4	(2x) 4.3-10 Female	1695-2700 MHz	Y5	13-14	(2x) 4.3-10 Female
1695-2700 MHz	Y1	5-6	(2x) 4.3-10 Female	1695-2700 MHz	Y6	15-16	(2x) 4.3-10 Female
1695-2700 MHz	Y2	7-8	(2x) 4.3-10 Female	3300-4200 MHz	P1	17-18	(2x) 4.3-10 Female
1695-2700 MHz	Y3	9-10	(2x) 4.3-10 Female	3300-4200 MHz	P2	19-20	(2x) 4.3-10 Female

Peter J. Tardy
09/02/2025
DATE

PETER J. TARDY, PE
NEW JERSEY PROFESSIONAL ENGINEER
LIC NO 41990

ENGINEER:

Camden Office:
2 Riverside Dr., Suite 503
Camden, New Jersey 08101
609.862.1582
FPAEngineers.com
New Jersey • New York • Pennsylvania • Massachusetts

OWNER/DEVELOPER:

The Foundation for a Wireless World.

TITLE:
CROWN CASTLE FIBER LLC
1267 GREAT ROAD
PRINCETON, NJ
JURISDICTION: MUNICIPALITY OF PRINCETON

REV.	DATE	REVISION DESCRIPTION
0	05/08/25	ISSUED FOR REVIEW
1	06/04/25	REVISED POLE HEIGHT
2	06/26/25	ISSUED AS FINAL
3	09/02/25	REVISED PER COMMENTS

DRAWN BY: ARC
CHECKED BY: ARC
APPROVED BY: PJT

PROJECT NUMBER: 2438C.212
NODE ID: PCT-015
SCU # / CASCADE ID: 410666/5000884478
DATE DRAWN: 05/08/25

SHEET: 8 of 9

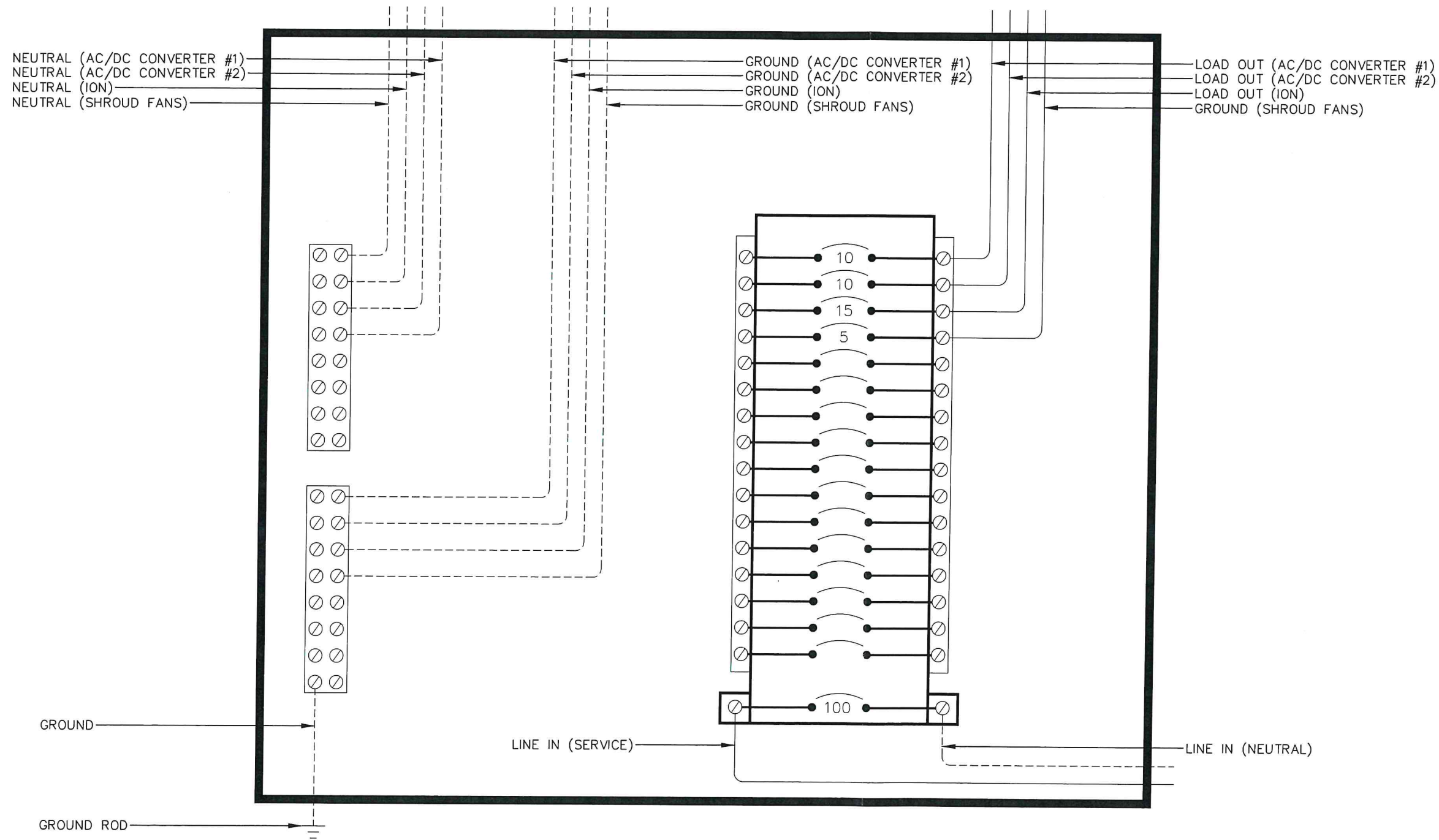

Peter J. Tardy

09/02/2025

PETER J. TARDY, PE
NEW JERSEY PROFESSIONAL ENGINEER LIC NO 41990

ENGINEER:



Camden Office:
2 Riverside Drive, Suite 503
Camden, New Jersey 08101
609.862.1582

FPAengineers.com

New Jersey New York Pennsylvania Massachusetts

OWNER/DEVELOPER:



The Foundation for a Wireless World.

TITLE:

CROWN CASTLE FIBER LLC
1267 GREAT ROAD
PRINCETON, NJ
JURISDICTION: MUNICIPALITY OF PRINCETON

REVISIONS

REV.	DATE	REVISION DESCRIPTION
0	05/08/25	ISSUED FOR REVIEW
1	06/04/25	REVISED POLE HEIGHT
2	06/26/25	ISSUED AS FINAL
3	09/02/25	REVISED PER COMMENTS

DRAWN BY:	CHECKED BY:	APPROVED BY:
ARC	ARC	PJT

PROJECT NUMBER:	2438C.212
NODE ID:	PCT-015
SCU # / CASCADE ID:	410666/5000884478
DATE DRAWN:	05/08/25

SHEET: 9 OF 9



Municipality of Princeton, NJ

400 Witherspoon St
Princeton, NJ 08540

Staff Report

File #: R-26-123

Agenda Date: 4/13/2026

Agenda #: 5.

Resolution of the Mayor and Council of Princeton Authorizing Change Order #1 with Colonnelli Brothers, Inc. in the Amount of \$314,670.00 for the Rehabilitation/Replacement of Two Pedestrian Footbridges in the Mountain Lakes Preserve, for a new Total Amount of the Construction Agreement of \$1,261,870.00

WHEREAS, the Mountain Lakes Red Trail bridge is a historic stone arch bridge dating to the time of the Princeton Ice Company's operations between 1884 and the 1920s; and

WHEREAS, the bridge was determined to be in a significant state of disrepair and, in 2021, an application was made to the New Jersey Historic Trust for a grant to offset the cost of the work required for rehabilitation; and

WHEREAS, the New Jersey Historic Trust awarded a grant of \$395,218.00 to Princeton to effect the rehabilitation of the Red Trail stone arch bridge; and

WHEREAS, designs for the rehabilitation of the Red Trail bridge and replacement of the Green Trail bridge were completed and bids were solicited and received in 2025: and

WHEREAS, by Resolution 25-138 adopted on April 14, 2025, Princeton Council awarded a contract to Colonnelli Brothers, Inc. for the Rehabilitation/Replacement of Two Pedestrian Footbridges in the Mountain Lakes Preserve for an amount not to exceed \$947,200.00; and

WHEREAS, upon commencement of work and dismantling of the bridge it was discovered that the stone arch and the wingwall footings were in a condition that was unforeseen at the time of design, including large stones protruding vertically above the stone arch and footings that were no longer in alignment to facilitate reconstruction of the wingwalls; and

WHEREAS, in order to fully evaluate the conditions, redesign the arch and new footings, and negotiate additional costs, Princeton suspended the work and Colonnelli Brothers, Inc. demobilized for the duration of the suspension; and

WHEREAS, negotiations between Princeton and Colonnelli Brothers, Inc., in good faith, resulted in a compromise of a reasonable cost to complete the additional work of remobilizing, demolition of the existing footings, forming and constructing new reinforced concrete footings, and constructing a modified reinforced concrete arch relief slab; and

WHEREAS, the negotiated cost of this construction due to unforeseen conditions is \$314,670.00, which is an increase of 33.221% of the original contract total, resulting in a new not-to-exceed construction contract amount of \$1,261,870.00; and

WHEREAS, Princeton has complied with the requirements of N.J.S.A. 40A:11-16.7 et seq. regarding changed

conditions for construction contracts and N.J.A.C. 5:30-11.9 et seq regarding the approval process for change orders which exceed the 20 percent limitation; and

WHEREAS, Princeton Engineering staff recommend authorizing Change Order #1 to Colonnelli Brothers Inc. in the amount of \$314,670.00 and an extension of time to complete the work of 120 days;

NOW, THEREFORE, BE IT RESOLVED by the Council of the Municipality of Princeton, County of Mercer, State of New Jersey, as follows

:

1. The Mayor and Council hereby authorize Change Order #1 to the contract with Colonnelli Brothers, Inc. for the Rehabilitation/Replacement of Two Pedestrian Footbridges in the Mountain Lakes Preserve Bid originally awarded by Resolution 25-138 on April 14, 2025, to increase the contract amount by \$314,670.00 for a new amount not to exceed \$1,261,870.00, and extend the time for the completion of work to 120 days.
2. The governing body will print a brief notice indicating the additional amount to be expended, the original contract price, the nature of the original and additional work, and why it is necessary to expend additional funds.
3. A copy of this Resolution and the Change Order Document shall be placed on file in the Office of the Clerk.



MUNICIPALITY OF PRINCETON

Department of Infrastructure
& Operations

400 Witherspoon Street

Princeton, NJ 08540

(609) 921-7077

engineering@princetonnj.gov

MEMORANDUM

To: Mayor and Council
From: James J. Purcell, PE, *Assistant Municipal Engineer*
Subject: Rehabilitation/Replacement of Two Pedestrian Bridges in the Mountain Lakes Preserve
Construction Contract Change Order
Date: April 10, 2026

Attached for consideration by Princeton Council at its April 13, 2026 meeting is a resolution to approve a Change Order to the Construction Contract for the Rehabilitation/Replacement of Two Pedestrian Bridges in the Mountain Lakes Preserve. This Change Order is necessary due to unforeseen conditions of the Red Trail bridge over Mountain Brook.

The Red Trail bridge is an historic stone arch bridge dating to the time of the Princeton Ice Company's operations between 1884 and the 1920s. While not listed as a specific historic structure, its significance contributes to the designation of the Mountain Lakes Preserve as an historic district. The bridge was determined to be in a significant state of disrepair and, in 2021, an application for its rehabilitation was made to the New Jersey Historic Trust (NJHT) for a grant to offset the cost of the work. NJHT awarded Princeton \$395,218 representing 50% of the estimated cost of rehabilitation of the stone arch bridge of \$790,435.

In addition to the rehabilitation of the Red Trail stone arch bridge, the bridge carrying the Green Trail over the stream by the upper Mountain Lake was in need of replacement. Construction documents were prepared by French & Parello Associates for both the replacement of the Green Trail Bridge and the rehabilitation of the Red Trail bridge.

Upon receipt of bids for the project, Council awarded a construction contract to Colonelli Brothers Inc. in April 2025 for an amount not to exceed \$947,200.00, \$648,300 of which was for the Red Trail Bridge. In August 2025, Colonelli completed the exacting work of dismantling the Red Trail bridge with each stone removed being marked for replacement in the same location. Upon completing the dismantling of the wingwalls, it was discovered that the footings for the walls were twisted out of alignment to the extent that the walls could not be reconstructed in a stable, secure manner and would need to be replaced. In addition, when the trail surface was removed from the stone arch structure, it was discovered that the arch consisted of mortared stone that protruded in varying degrees above the arch. The reconstruction of the bridge includes a reinforced concrete stress relief slab that was to be constructed above the stone arch. This stress relief slab was not designed to compensate for these protrusions and required redesign with more reinforcing steel and additional concrete.

Colonelli Brothers continued work on the Green Trail bridge while the Red Trail bridge was redesigned. Upon review of the changes, in early December 2025, Colonelli requested a change in the amount of \$386,000.00. Recognizing that potentially protracted negotiations might ensue and to avoid delay claims by Colonelli, we issued a stop work order until such time as an agreement could be reached. Negotiations took place in March and we agreed that:

1. The additional work was due to unforeseen conditions;
2. The work stoppage was due to Princeton's invoking the contractual clause allowing such

stoppage;

3. Colonelli Brothers is entitled to compensation for remobilizing equipment and personnel, and the mobilization will require reconstruction of an access road to reach the site, re-establishment of cofferdams, re-establishment of soil erosion and sediment control fencing, and establishment of stable platforms for equipment; and
4. The removal of the existing and construction of new footings would require methods not anticipated in the original design or bid, requiring multiple concrete pours and pump trucks.

In accordance with the General Conditions of the Agreement, and in keeping with State law, if the quantity for an item changes by more than 20%, the unit price is subject to a negotiated change in price. The Change Order included five items with increases in quantities over 20%. Colonelli agreed to hold the unit prices on four of these and will be paid based on the actual quantity constructed at the price bid. The remaining item, Concrete Footing, was negotiated due to the complexity, as stated above, of the means and methods necessary to construct. In addition, there were three items that were not included in the original bid – Remobilization, Demolition of Footings, and Coarse Aggregate Layer for the footing bedding. Engineering staff reviewed the quantities and costs for all the items and deemed them to be reasonable.

In considering all alternatives, Engineering staff also investigated whether it was reasonable to cancel the contract and not complete the reconstruction. The consequences of such cancellation would be the loss of the New Jersey Historic Trust Grant of \$395,218.00, an undetermined cost to remove the cofferdams and silt fence and restore the streambanks, securing and storing the historic stones currently stockpiled on site, and permanent closure of the Red Trail.

An application for a grant to offset the additional cost is being prepared for submission to the NJHT. The NJHT Capital Level II grant is on a 1:1 match basis and the request will be for \$157,355.00.

Engineering staff performed an analysis of invoices to date and expected costs to complete and anticipates that there will be savings in other items on the overall project that sum to approximately \$170,000.00. The table below summarizes the anticipated costs, with an assumption of the second grant being awarded:

	Red Trail Bridge	Green Trail Bridge	Total Contract
Original Contract	\$648,300.00	\$298,900.00	\$947,200.00
Change Order 1 (This C.O.)	\$314,670.00		\$314,670.00
NJHT Grant (Original)	(\$395,218.00)		(\$395,218.00)
NJHT Grant (to be applied for)	(\$157,355.00)		(\$157,355.00)
Anticipated Savings		(\$170,000.00)	(\$170,000.00)
Projected Cost to Princeton			\$539,297.00

In consideration of the above, it is recommended that the Change Order in the amount of \$314,670 be approved and that the total not-to-exceed amount of the contract with Colonelli Brothers Inc. be increased to \$1,261,870.00. The Change Order is attached.

CHANGE ORDER

REHABILITATION/REPLACEMENT OF TWO PEDESTRIAN FOOTBRIDGES IN THE MOUNTAIN LAKES PRESERVE



PROJECT:

*Rehabilitation/Replacement
of Two Pedestrian
Footbridges in the Mountain
Lakes Preserve*

OWNER:

*Princeton Municipality
400 Witherspoon Street
Princeton, NJ 08540*

CONTRACT INFORMATION:

*Award
Date: April 14, 2025*

ENGINEER/DESIGNER:

*French & Parello Associates
1800 Route 34, Suite 101
Wall, NJ 07719*

**CHANGE ORDER
INFORMATION:**

Change Order Number: 1

Date: April 13, 2026

**CONSTRUCTION
MANAGER:**

N/A

CONTRACTOR:

*Colonnelli Brothers Inc.
409 South River Street,
Hackensack, NJ 07601*

THE CONTRACT IS CHANGED AS FOLLOWS:

This change order is for replacement of the footings and a modification to the arch relief slab for the Red Trail Bridge. Upon inspection, the existing condition of the footings are deficient to be able to proceed with the rehabilitation if not repaired. After the removal of the outer layer stones on the bridge, the arch relief slab design required extensive design changes that included additional items that were not in the original contract.

INCREASE/DECREASE IN ITEM QUANTITY

ITEM	DESCRIPTION	ORIGINAL BID QTY	UNIT	UNIT PRICE	CHANGE ORDER QTY	CHANGE ORDER EXTENSION
16	EXCAVATION, UNCLASSIFIED	441	CY	\$60.00	110	\$6,600.00
38	CONCRETE FOOTING	11	CY	\$1,200.00	2.2	\$2,640.00
40	CONCRETE ARCH RELIEF SLAB	20	CY	\$1,650.00	8	\$13,200.00
49	REINFORCEMENT STEEL, GALVANIZED	5000	LB	\$3.00	4500	\$13,500.00

Total amount changed as a result of item quantity changes is \$35,940.00.

INCREASE/DECREASE IN ITEM QUANTITY & UNIT PRICE

ITEM	DESCRIPTION	ORIGINAL BID QTY	UNIT	ADJUSTED UNIT PRICE	CHANGE ORDER QTY OVER 20%	CHANGE ORDER EXTENSION
38	CONCRETE FOOTING	11	CY	\$3,850.00	61.8	\$237,930.00

Total amount changed as a result of item quantity and unit price changes is \$237,930.00.



ADD THE FOLLOWING CONTRACT ITEMS USING CONTINGENCY FUNDING

ITEM	DESCRIPTION	ORIGINAL BID QTY	UNIT	UNIT PRICE	CHANGE ORDER QTY	CHANGE ORDER EXTENSION
S1	REMOBILIZATION	0	LS	\$30,400.00	1	\$30,400.00
S2	DEMOLITION OF FOOTINGS/CONTAINER	0	LS	\$9,000.00	1	\$9,000.00
S3	COARSE AGGREGATE LAYER	0	CY	\$100.00	14	\$1,400.00

The total amount using contingency funds as a result of construction change directives is \$40,800.00.

The original Contract Sum was	\$947,200.00
Net change by previously authorized Change Orders	\$0.00
The Contract Sum prior to this Change Order was	\$947,200.00
The Contract Sum will be increased by this Change Order in the amount of	\$314,670.00
The new Contract Sum including this Change Order will be	\$1,261,870.00
The Contract Time will be increased by one hundred twenty (120) days.	
The Contractor's Work shall be substantially complete on August 6, 2026.	

NOTE: This Change Order does not include adjustments to the Contract Sum or Guaranteed Maximum Price, or the Contract Time, that have been authorized by Construction Change Directive until the cost and time have been agreed upon by both the Owner and Contractor, in which case a Change Order is executed to supersede the Construction Change Directive.

NOT VALID UNTIL SIGNED BY THE ENGINEER, CONSTRUCTION MANAGER, CONTRACTOR, AND OWNER.

_____ ENGINEER (Firm name)	_____ CONSTRUCTION MANAGER (Firm name)
_____ SIGNATURE	_____ SIGNATURE
_____ PRINTED NAME AND TITLE	_____ PRINTED NAME AND TITLE
_____ DATE:	_____ DATE:
_____ CONTRACTOR (Firm name)	_____ OWNER (Firm name)
_____ SIGNATURE	_____ SIGNATURE
_____ PRINTED NAME AND TITLE	_____ PRINTED NAME AND TITLE
_____ DATE:	_____ DATE:



1800 Route 34, Suite 101
Wall Township, New Jersey 07719
T: 732.312.9800
F: 732.312.9801
fpaengineers.com

April 9, 2026

Ms. Deanna Stockton, PE, CME
Municipal Engineer / Deputy Administrator
Department of Infrastructure & Operations
MUNICIPALITY OF PRINCETON
400 Witherspoon Street
Princeton, New Jersey 08540

Attn: Mr. James J. Purcell, PE

RE: Certification of Change Order to replace footings and modify arch relief slab
REHABILITATION / REPLACEMENT OF TWO PEDESTRIAN FOOTBRIDGES
(Historic Stone Arch (Red Trail) & Stone/Conc. Footbridge (Green Trail))
Mountain Lakes Preserve
Princeton, Mercer County, New Jersey
FPA No. 17045.009

Dear Mr. Purcell,

As requested, this letter is to certify that there are changed conditions due to unforeseen circumstances that require issuance of a Change Order for the replacement of the footings and a modification to the arch relief slab for the Historic Stone Arch Footbridge on the Red Trail Bridge in the referenced project. The proposed Change Order is necessary due to unforeseen conditions encountered during construction for the rehabilitation of the historic footbridge.

At the time of design, the existing condition of the bridge footings could not be accurately assessed due to the absence of as-built plans and since the footings were fully buried and inaccessible for inspection.

Following the removal of the fill above the stone arch and between the stone masonry spandrel walls exposing the existing footings during construction, it was determined that the footings were inadequate to support the rehabilitated structure. Once the construction activities exposed the footings and the arch, FPA inspected the bridge on October 2, 2025, and found that the existing footing widths varied between 21" and 24" wide, which were not adequate for the spandrel walls. This explained why the existing footings cracked at the junction with the arch footings resulting in the original spandrel walls shifting outward (sliding) and the walls rotating. The stone arch was also composed of vertically placed stones with the extrados of varying height. It is noted that the footings for the spandrel walls and the stone arch were buried and in an unknown condition. New wider reinforced concrete footings with adequate depth below the frost line for the four (4) spandrel walls were subsequently recommended in our October 3, 2025 email. In addition, the geometry for the top of the concrete arch relief slab needed to be redesigned to enable the reinforcement steel placement.

These conditions could not reasonably have been foreseen during the design phase because the footings were not visible and no reliable record drawings existed documenting their dimensions or condition.



Therefore, Issuance of this change order is necessary to replace the existing footings and provide properly sized and stable foundations. This work will also allow the arch structure to be rehabilitated safely and in accordance with the structural and quality standards expected by the Municipality of Princeton and New Jersey Historic Trust. The proposed Change Order is in the best interest of the Municipality of Princeton and does not abuse the Change Order rules. This work will ensure long-term stability and proper rehabilitation of the bridge, while addressing conditions that were not reasonably identifiable prior to construction.

If you should have any questions or comments, please contact me at (732) 539-3022 or by email.

Respectfully submitted,
FRENCH & PARRELLO ASSOCIATES

A handwritten signature in blue ink that reads "William C. Pyontek".

William C. Pyontek, PE, PP
Chief Engineer – Bridges
William.Pyontek@FPAengineers.com



4/9/2026
Hackensack, NJ

Mr. James J. Purcell, PE
Assistant Municipal Engineer / Acting Land Use Engineer
Municipality of Princeton
400 Witherspoon Street
Princeton, NJ 08540

**RE: Certification of Changed Conditions and Request for Change Order -
REHABILITATION/REPLACEMENT OF TWO PEDESTRIAN FOOTBRIDGES**

Dear James,

Pursuant to the requirements of the Qualified Purchasing Agent and New Jersey Administrative Code regarding municipal contract modifications, Colonnelli Brothers Inc is providing this formal certification regarding the necessity of a Change Order for the above-referenced project.

Explanation of Facts

During the repair works on red trail bridge the greater than expected undermining of existing structure was exposed. The existing substructure of the stone wing walls was found to be unacceptable. In order to eliminate any future failure the design engineer FPA presented the plan to remove the walls completely and install new stepped concrete footing to support new walls.

Statement of Unforeseen Circumstances

We hereby certify that these conditions were entirely unforeseen and could not have been reasonably anticipated at the time of the original bid or contract execution. The substructure conditions were not evident and only appeared after excavation. This issue was not disclosed in the project's technical specifications or plans.



Best Interests of Princeton

It is our professional opinion that issuing this Change Order is in the best interests of the Municipality of Princeton. This modification ensures structural stability of renovated bridge while preventing future remediation that would be required otherwise. This request is made in good faith to address specific physical conditions of the project site and does not constitute an abuse of the change order rules.

Should you require any additional documentation or a line-item cost breakdown to support this certification, please let us know.

Sincerely,

Lukas Prokop, DoO



Staff Report

File #: R-26-124

Agenda Date: 4/13/2026

Agenda #: 6.

Resolution Authorizing the Submittal of a Preserve New Jersey Capital Level II Grant Application for the Project “Rehabilitation of a Historic Stone Arch Bridge at the Mountain Lakes Preserve, Committing to the Dedication of \$157,335 in Matching Funds, and Authorizing Municipal Representatives to Sign the Assurances Documentation

WHEREAS, the seventy-eight-acre Billy Johnson Mountain Lakes Preserve (Preserve) is owned by the Municipality of Princeton and maintained by the Friends of Princeton Open Space (FOPOS) for public passive recreation opportunities including hiking on its miles of trails; and

WHEREAS, the Princeton Ice Company (ID#4716), a designated historic site on the State and National Registers of Historic Places, operated an ice production, harvesting and storage operation within the lands now encompassed by the Preserve in the late 1800s and early 1900s; and

WHEREAS, in 2012 and 2013, the former Township of Princeton undertook an award-winning multi-million-dollar project to dredge two lakes and reconstruct the Upper Setting Pond Dam, the Upper Mountain Lakes concrete and argillite Dam, and the Lower Earthen Dam at the Preserve; and

WHEREAS, there is a Concrete and Argillite Arched Footbridge (Footbridge) on the Preserve’s Red Trail that was not individually listed as a contributing resource when the Princeton Ice Company was designated as a historic site; however, it appears to use the same materials and construction methods employed in the historic Upper Mountain Lakes concrete and argillite Dam; and

WHEREAS, the Footbridge was identified to be in structurally poor condition due to varying degrees of erosion at the arched bridge footings, substandard parapets, leaning and / or misaligned spandrel walls, and other surficial mortar issues; and

WHEREAS, on April 12, 2021, the Municipality of Princeton contracted with French & Parrello Associates, P.A., the consulting firm which designed the Mountain Lakes Dams reconstruction project, to prepare the permitting and construction plans for the rehabilitation of the Footbridge; and

WHEREAS, the Princeton Historic Preservation Commission endorsed the submittal of a grant application entitled “Rehabilitation of a Historic Stone Arch Bridge at the Mountain Lakes Preserve” for this Footbridge at its meeting on April 19, 2021.

WHEREAS, the Municipality of Princeton sought and obtained a grant of \$395,218.00 from the New Jersey Historic Trust to offset some of the estimated design and construction costs associated with the rehabilitation of the Footbridge through the acquisition of grant funds from the New Jersey Historic Trust Preserve New Jersey Capital Level II Historic Preservation Fund program; and

WHEREAS, the Municipality of Princeton awarded a construction contract to Colonelli Brothers Inc. in April 2025 for the “Rehabilitation/Replacement of Two Pedestrian Bridges in the Mountain Lakes Preserve,” which included replacement of a second footbridge, for an amount not to exceed \$947,200.00, \$648,300 of which was for the Red Trail Bridge; and

WHEREAS, unforeseen conditions of the footings and stone arch below ground resulted in a change order for an additional \$314,670 to Colonelli Brothers to construct new footings and a modified concrete arch to relieve stress on the historic stone arch; and

WHEREAS, the Municipality of Princeton seeks to offset some of the additional construction costs associated with the unforeseen conditions and additional rehabilitation of the Footbridge through the acquisition of grant funds from the New Jersey Historic Trust Preserve New Jersey Capital Level II Historic Preservation Fund program; and

WHEREAS, the Municipality of Princeton commits to providing the required minimum 1:1 match to the Level II grant funds up to \$157,335.00; and

WHEREAS, the Chief Financial Officer has certified that sufficient funds are available in the account 04-215-24-014-076-336; and

NOW, THEREFORE, BE IT RESOLVED, by the Mayor and Council of Princeton as follows:

1. The Municipal Engineer is authorized to file a New Jersey Historic Trust Preserve New Jersey Capital Level II Historic Preservation Fund grant application for the “Rehabilitation of a Historic Stone Arch Bridge at the Mountain Lakes Preserve” under the project entitled “Rehabilitation/Replacement of Two Pedestrian Bridges in the Mountain Lakes Preserve”.
2. The Mayor and Municipal Engineer are authorized and directed to sign the assurances and acknowledge the certification contained in said assurances.
3. The Mayor and Municipal Engineer are authorized to execute such other agreements on behalf of the Municipality of Princeton, as may be required for submittal of the grant application and execution of future grant agreements in connection herewith.
4. The required minimum 1:1 match (up to \$157,335) to the requested grant funds is hereby appropriated out of the account 04-215-24-014-076-336 to pay for the “Rehabilitation of a Historic Stone Arch Bridge at the Mountain Lakes Preserve” within the required grant timeframe.
5. The Footbridge shall be nominated as a contributing resource to the Princeton Ice Company historic site as required.
6. The Municipality shall abide by “The Secretary of the Interior’s Standards for the Treatment of Historic Properties With Guidelines for Preserving, Rehabilitating, Restoring & Reconstructing Historic Buildings” in performing funded work.



Municipality of Princeton, NJ

400 Witherspoon St
Princeton, NJ 08540

Staff Report

File #: R-26-125

Agenda Date: 4/13/2026

Agenda #: 7.

Resolution of the Mayor and Council of the Municipality of Princeton Authorizing the Award of a Contract to HG Media for 2026 Princeton Podcast Sponsorship for an Amount Not to Exceed \$7,800.00

WHEREAS, the Municipality of Princeton wishes to sponsor the Princeton Podcast in 2026; and

WHEREAS, HG Media provided a proposal for these services for an amount not to exceed \$7,800.00, to be paid in quarterly installments of \$1,950.00; and

WHEREAS, the Certified Financial Officer has certified that the Municipality of Princeton has appropriated sufficient funds for these services in account 01-201-20-111-283; and

WHEREAS, the podcast is hosted by the Mayor, who uses the podcast for purposes of providing municipal information to the Princeton community; and

WHEREAS, the term of this contract shall be twelve months.

NOW, THEREFORE, BE IT RESOLVED by the Mayor and Council of the Municipality of Princeton, County of Mercer, State of New Jersey, as follows:

1. The Mayor and Council, or their designee, are hereby authorized and directed to enter into an agreement with HG Media to Sponsor the Princeton Podcast in 2026 for an amount not to exceed \$7,800.00.
2. The Term of this contract shall be twelve months.
3. A copy of this Resolution and contract will be kept on file in the Office of the Clerk.

Princeton Podcast 2026 Sponsorship Agreement

Princeton Podcast – 2026 Annual Sponsorship

This Agreement is made between **HG Media**, represented by **Kenneth Greenberg, Princeton Podcast Producer**, and the **Municipality of Princeton**, represented by **Bernard Hvozdovic Jr., Municipal Administrator**.

1. Purpose of Agreement

The **Municipality of Princeton** agrees to serve as the **exclusive 2026 Sponsor** of ***The Princeton Podcast***, produced and published by **HG Media**.

2. Term of Agreement

The sponsorship will cover the period **January 1, 2026 through December 31, 2026**, inclusive.

3. Sponsorship Benefits

During the term of this Agreement:

1. **One sponsorship announcement** will be included in the **introduction of each of the 12 monthly podcast episodes** published in 2026.
2. The sponsorship language to be used is:
“This episode of The Princeton Podcast is sponsored by the Municipality of Princeton, encouraging civic participation and amplifying the voices that shape our community.”
3. The same sponsorship statement will be included in the **episode description** accompanying each published episode on the **Princeton Podcast website**.

4. Production & Implementation

The sponsorship will be implemented and managed by:

Kenneth Greenberg, Podcast Producer
HG Media – Production Director
12 Fisher Avenue, Princeton, New Jersey

5. Sponsorship Fee & Billing Schedule

The Municipality of Princeton agrees to an **annual sponsorship fee of \$7,800.00.**

Payment will be invoiced **quarterly**, as follows:

- **\$1,950** invoiced **March 1, 2026** (for Q1 2026)
- **\$1,950** invoiced **June 1, 2026** (for Q2 2026)
- **\$1,950** invoiced **September 1, 2026** (for Q3 2026)
- **\$1,950** invoiced **December 1, 2026** (for Q4 2026)

Invoices are payable in accordance with the Municipality's standard payment terms.

6. Ownership & Distribution

HG Media retains all property rights and distribution responsibilities for *The Princeton Podcast*. Episodes will be made publicly available via the Princeton Podcast website and primary podcast platforms including Spotify and Apple Podcasts.

7. Analytics and Reporting:

HG Media agrees to provide the Sponsor with a biannual, one-page podcast performance report to evaluate the reach of the podcast. This report will include:

- **Total Listens/Downloads:** Aggregated across all podcast platforms where the show is distributed including Apple Podcasts Spotify, and PrincetonPodcast.com.
- **Estimated Audience Size:** Based on unique download metrics provided by our podcast hosting platform.
- **Audience Engagement:** Average listening time and completion rates, sourced exclusively from Apple Podcasts and Spotify dashboards, subject to the data availability provided by those specific platforms.

8. Deliverables:

The Princeton Podcast is distributed to all major podcast distribution channels through our 2 primary platforms; Apple Podcasts and Spotify. The podcast is also embedded on the PrincetonPodcast.com website.

For each of the monthly podcast episodes published, HG Media will produce one 9:16 (vertical) audio/visual reel. This promotional media will be distributed across the following social media platforms:

- **Instagram:** Posted on the Princeton Podcast Instagram page as a collaborative post with the Mayor Mark Freda and Princeton Municipality pages.
- **Facebook:** Posted on the Princeton Podcast Facebook page.
- **LinkedIn:** Posted on the HG Media LinkedIn page to be reposted by Producer Kenneth Greenberg.

Agreement Acceptance

By signing below, both parties agree to the terms outlined in this document.

For the Municipality of Princeton

Name: Bernard Hvozdovic Jr.
Title: Municipal Administrator

Signature: _____ **Date:** _____

For HG Media

Name: Kenneth Greenberg
Title: Production Director, HG Media

Signature: _____ **Date:** _____



Municipality of Princeton, NJ

400 Witherspoon St
Princeton, NJ 08540

Staff Report

File #: R-26-126

Agenda Date: 4/13/2026

Agenda #: 1.

Resolution of the Mayor and Council of Princeton Authorizing the Payment of Bills and Claims

WHEREAS, Chief Financial Officer, Sandra Webb has forwarded the bills and claims received for payment by the Municipality of Princeton for review and approval by the Mayor and Council.

NOW, THEREFORE BE IT RESOLVED that the Mayor and Council of Princeton approve the attached bill list.

List of Bills - Clearing Claims

Meeting Date: 04/13/2026 For bills from 03/24/2026 to 04/09/2026

Vendor	Description	Payment	Check Total
1247 - ALldata LLC	PO 48803 ANNUAL RENEWAL	1,500.00	1,500.00
5271 - AMAZON CAPITAL SERVICES	PO 48557 Blanket 2026	227.97	227.97
5379 - AMIT BARIA	PO 49051 REFUND OF ESCROW FEES- APPLICATION FOR Z	750.00	
	PO 49051 REFUND OF ESCROW FEES- APPLICATION FOR Z	240.00	990.00
2630 - APRUZZESE, MCDERMOTT, MASTRO	PO 48661 2026 LABOR COUNSEL LEGAL SERVICES	1,709.63	1,709.63
4375 - ARCADIS US, INC.	PO 42013 RESOLUTION # 2023-299	736.50	
	PO 44317 RESOLUTION 2024-185	80,377.00	
	PO 46706 RESOLUTION 25-192 MINI SYSTEM 36 A,B,C,	28,031.68	109,145.18
4874 - ARORA AND ASSOCIATES, P.C.	PO 46269 RESOLUTION 25-110 DESIGN SVCS FOR STONY	8,918.00	8,918.00
57 - AT&T	PO 48975 Telephone - Acct 030 175 6429 001 - Bill	42.95	42.95
2003 - BARR, R. DONALD	PO 49074 1st Qtr 2026 Medicare	5,104.23	5,104.23
2642 - BEANS, FRED PARTS, INC	PO 48145 BLANKET PARTS TV	766.68	766.68
63 - BISH SALES & SERVICE INC	PO 48273 BLANKET	80.00	80.00
4603 - BLOODGOOD LAW ENFORCEMENT TRAINING GROUP	PO 48626 TRAINING	975.00	975.00
3315 - BOWMAN CONSULTING GROUP, LTD.	PO 48941 TRAFFIC CONSULTING ATTENDING ZBA MEETING	2,590.00	
	PO 48949 ADDITIONAL TRAFFIC REVIEW FOR PRINCETON	2,806.25	5,396.25
463 - BRITTON INDUSTRIES, INC.	PO 48274 BLANKET	1,509.30	1,509.30
4341 - BUILDING SAFETY CONFERENCE OF NJ, INC.	PO 48895 BUILDING SAFETY CONFERENCE REGISTRATION	650.00	
	PO 48961 BUILDING SAFETY CONF. REGISTRATION FOR D	325.00	975.00
1342 - BURLINGTON COUNTY EMERGENCY SERVICE	PO 48431 TRAINING FOR THE DEPARTMENT	90.00	90.00
5237 - CAMIROS LTD	PO 47223 RESOLUTION 25-284 PHASE 1 OF UNIFIED ZON	2,670.00	2,670.00
4009 - CANON U.S.A., INC.	PO 48464 Blanket - 2026 Canon	335.73	335.73
86 - CAOLA COMPANY	PO 48278 BLANKET	16.00	16.00
4882 - CATHOLIC CHARITIES DIOCESE	PO 48069 RESO 26-5 2026 BEHAVIORAL HEALTH AND COM	4,680.76	4,680.76
3244 - CLARKE CATON HINTZ	PO 48104 2026 AFFORDABLE HOUSING MONITORING SERVI	2,295.00	2,295.00
263 - COMCAST CORPORATION	PO 49043 Comcast - Acct. 8499 05 310 0050723 - Bi	140.65	140.65
263 - COMCAST CORPORATION	PO 49073 Comcast - Acct. 8499 05 310 0062793 - Bi	40.01	40.01
263 - COMCAST CORPORATION	PO 49082 Comcast - Acct. 8499 05 311 0085701 - Bi	234.06	234.06
109 - CONTINENTAL FIRE & SAFETY	PO 48952 INTERCEPTOR POWER BIKE BLACK/750-1,000 M	243.00	
	PO 48952 INTERCEPTOR POWER BIKE BLACK/750-1,000 M	5,000.00	5,243.00
5367 - CORE EQUIPMENT GROUP	PO 48962 BLANKET PARTS/SERVICE TV	2,394.76	2,394.76
4663 - CORPORATE BILLING	PO 48137 BLANKET PARTS/SERVICE TV	1,653.51	1,653.51
4604 - COSTELLO'S ACE HARDWARE	PO 48206 BLANKET/SUPPLIES	42.93	
	PO 48223 BLANKET - SUPPLIES	196.30	
	PO 48291 BLANKET	359.61	
	PO 48292 BLANKET	129.96	
	PO 48295 BLANKET	144.84	
	PO 48460 GENERAL SUPPLIES	13.99	887.63
117 - CRESTON HYDRAULICS INC.	PO 48140 BLANKET TV	878.18	878.18
1067 - CUDA METRO SERVICE LLC	PO 48123 RIVER ROAD OIL HEATER REPAIR	1,787.25	1,787.25
1849 - CUSTOM BANDAG, INC.	PO 48139 BLANKET TIRES TV	198.00	198.00
5374 - DANA DEFIGUEIREDO	PO 49001 ESCROW REFUND 17-290-20-024-579	121.00	121.00
1453 - DANIEL DOBROMILSKY & ASSOCIATES	PO 49012 MAJOR SITE PLAN LANDSCAPE REVIEW FOR 344	437.50	437.50
4292 - DOMINICK ITZI	PO 48967 2026 SHOE REIMBURSEMENT	250.00	250.00
5122 - DYNAMIC SECURITY, LLC	PO 48834 #184265	625.73	625.73
4005 - EARLE ASPHALT COMPANY	PO 47049 RESOLUTION 25-247 IMPROVEMENTS TO MT LUC	116,966.40	116,966.40
1256 - EASTERN ARMORED SERVICES, INC.	PO 48086 RESO 24-325 2026 ARMORED CAR SERVICES	10,128.00	10,128.00
3835 - EASTERN WAREHOUSE DISTRIBUTORS	PO 48143 BLANKET PARTS/OILS TV	868.73	868.73
4693 - EMMANUEL SANTOS-ROBLES	PO 48944 REIMBURSE LODGING 2026 NJEHA ANNUAL CONF	219.58	219.58
1804 - ENVIRONMENTAL MANAGEMENT ASSOC	PO 47915 PHASE I ENVIRONMENTAL INVESTIGATION - 30	6,925.00	6,925.00
147 - FASTSIGNS INC.	PO 48963 WHITE DIE CUT VINYL APPLIED TO EXISTING	179.00	179.00
148 - FIRE & SAFETY SERVICES, LTD.	PO 48222 BLANKET - SERVICES	4,789.77	4,789.77
5159 - FIRSTLINE LOCKSMITH LLC	PO 48301 BLANKET	47.50	47.50
3189 - FLEXFACTS.COM	PO 48511 Blanket 2026	68.00	68.00
4879 - FP MAILING SOLUTIONS	PO 48055 POSTAGE LEASE 12/23/25 - 12/22/26 1 MONU	104.85	104.85
395 - FRENCH & PARELLO ASSOCIATES,PA	PO 45955 RESOLUTION 2025-65 CONSTRUCTION ADMINIST	3,041.25	
	PO 48059 RESO 25-237 CONSTRUCTION ADMINISTRATION	25,012.50	28,053.75
1773 - GABRIELLI TRUCK SALES, LTD	PO 48146 BLANKET PARTS/SERVICE TV	347.48	347.48
158 - GALLS LLC	PO 48190 UNIFORMS	760.86	
	PO 48190 UNIFORMS	354.34	
	PO 48868 BLANKET - UNIFORMS	2,897.99	

List of Bills - Clearing Claims

Meeting Date: 04/13/2026 For bills from 03/24/2026 to 04/09/2026

Vendor	Description	Payment	Check Total
	PO 48869 BLANKET - UNIFORMS	1,289.86	5,303.05
159 - GANN LAW BOOKS	PO 48943 2026 EDITION NJ ZONING & LAND USE ADMINI	209.00	
	PO 49048 2026 NJ Zoning & Land Use Book	609.00	818.00
5092 - GEBHARDT & KIEFER, P.C.	PO 45270 RESOLUTION 25-29: CONFLICT COUNSEL LEGAL	561.00	561.00
2645 - GEN-EL SAFETY & INDUSTRIAL PROD, LL	PO 48825 ITEM #20-8326856 - BATTERY PAC6000/8000	835.30	835.30
170 - GRAINGER	PO 45741 BLANKET/SUPPLIES	2,728.87	
	PO 48214 BLANKET - TOOLS/SUPPLIES	473.97	
	PO 48668 BLANKET	1,239.76	
	PO 48669 BLANKET	1,266.78	5,709.38
1371 - GREENBAUM, ROWE, SMITH, DAVIS	PO 48858 RESO 26-77 - 2026 REDEVELOPMENT COUNSEL	15,167.00	15,167.00
4741 - HARD ROCK HOTEL & CASINO	PO 49033 NJLom Conference of Mayors 5/19/26-5/21/	225.00	225.00
4878 - HARRAH'S ATLANTIC CITY OPERATING COMPANY	PO 48896 JANELL COLOMBO ACCOMODATION DURING CONFE	464.00	
	PO 48960 DALE GATES ACCOMODATION DURING COONFEREN	232.00	696.00
191 - HOME DEPOT CREDIT SERVICES	PO 49023 GENERAL SUPPLIES	167.22	167.22
2617 - HOMECARE VETERINARY SERVICES LLC	PO 48918 BLANKET 2026	627.79	627.79
1930 - HUGHES, JEFF	PO 48968 2026 SHOE REIMBURSEMENT	250.00	250.00
3228 - HURLEY, ADAM	PO 48908 ANNUAL CLOTHING ALLOWANCE (NOT TO EXCEED	400.00	400.00
5350 - HUTCHINS HVAC INCORPORATED	PO 48702 BLANKET	1,166.52	1,166.52
3960 - INDUSTRIAL WELDING SUPPLY, INC.	PO 48149 BLANKET WELDING SUPPLIES TV	179.80	179.80
4920 - INGA REICH	PO 48998 2026 SHOE REIMBURSEMENT	250.00	250.00
2690 - INTERSTATE BATTERY OF PRINCETON	PO 48150 BLANKET BATTERIES TV	423.85	423.85
3729 - IPS GROUP INC.	PO 48637 2026 BLANKET PARKING METER CREDIT CARD F	20,236.53	20,236.53
2616 - J. HARRIS ACADEMY OF POLICE TRAININ	PO 48463 OFFICER TRAININGS	595.00	595.00
5363 - JAMIE CHRISTINE LUNGU	PO 48980 Sign Language Interpretation Services fo	335.25	335.25
201 - JAMMER DOORS	PO 48643 BLANKET - 2026 REPAIRS	450.00	450.00
204 - JEFECO	PO 48317 BLANKET	108.00	108.00
1649 - JERSEY ELEVATOR, LLC	PO 48725 MAINTENANCE CONTRACT	6,242.09	6,242.09
4876 - JERSEY MAIL SYSTEMS	PO 48698 INK FOR POSTAGE MACHINE	290.90	290.90
3621 - JET VAC EQUIPMENT, LLC	PO 46962 RESO 25-236/25-249 800-HPR ECO SERVICES	242,640.82	242,640.82
2282 - JOHN F MCCARTHY III	PO 49016 Special Parking Session Thursday March 1	750.00	750.00
539 - JOHN KURTZ JR INC	PO 48539 BLANKET - SERVICE	437.62	437.62
4507 - JOHNSON, MARK	PO 48981 2026 Eyeglass Reimbursement Warby Parke	150.00	150.00
1238 - JOHNSON, MIRMIRAN & THOMPSON, INC.	PO 42511 RESOLUTION 2023-405	494.96	494.96
2653 - JOSEPH MATTICOLI	PO 48882 IA EI 2026 NEC CODE UPDATE TRAINING	225.00	225.00
3831 - JPMONZO MUNICIPAL CONSULTING	PO 49047 WHAT DO THE TEXTBOOKS NOT TEACH YOU, WEB	160.00	160.00
4888 - KG LAW GROUP LLC	PO 48487 RESO 26-40 MUNICIPAL PROSECUTOR	600.00	
	PO 48487 RESO 26-40 MUNICIPAL PROSECUTOR	14,400.00	15,000.00
1616 - KNESKI, PETER A.	PO 49026 1ST QTR 2026 Medicare Retiree	5,391.71	5,391.71
75 - KOVI TOWING LLC	PO 48152 BLANKET TOWING	428.85	428.85
2903 - KYOCERA DOCUMENT SOLUTIONS	PO 48465 2026 Blanket - Kyocera	972.00	972.00
1606 - LAKE, HENRY	PO 48964 2026 SHOE REIMBURSEMENT	250.00	250.00
227 - LANGUAGE LINE SERVICES	PO 48603 TELEPHONE TRANSLATION SERVICES	916.87	916.87
228 - LAWSON PRODCTS, INC	PO 48153 BLANKET PARTS/SUPPLIES TV	294.27	294.27
5132 - LEXIPOL, LLC	PO 48880 TRG STATE ANNUAL ACCREDITATION MANAGEMEN	9,585.14	9,585.14
4672 - LOBIANCO, VERA	PO 48737 2026 PUBLIC HEALTH NURSING SERVICES	2,925.00	2,925.00
694 - LUIS NAVAS	PO 48953 ENHANCED RECRUITMENT VIDEO PLACEMENT	53.73	53.73
379 - MAGIC TOUCH CONSTRUCTION CO IN	PO 48335 BLANKET-ELECTRICAL BUILDINGS AND GROUNDS	1,707.35	
	PO 48339 BLANKET/PLUMBING BUILDINGS AND GROUNDS E	6,404.06	
	PO 48340 BLANKET/PLUMBING SPRING STREET GARAGE ES	1,148.70	9,260.11
250 - MAHER, BRIAN	PO 48965 2026 SHOE REIMBURSEMENT	250.00	250.00
1570 - MAJESTIC OIL COMPANY	PO 48343 BLANKET	17,571.56	17,571.56
5124 - MAVIS TIRE SUPPLY LLC	PO 48155 BLANKET SERVICE TV	150.00	150.00
1553 - MCCAFFREYS MARKET	PO 48476 BLANKET PO	265.72	
	PO 48498 BLANKET - FOOD, WATER, & SUPPLIES FOR PR	226.84	
	PO 48871 FOOD	36.96	529.52
266 - MCMASTER-CARR	PO 48229 BLANKET/ PARTS /MATERIALS	394.07	394.07
277 - MERCER COUNTY HEALTH OFFICERS ASSOC.	PO 49019 2026 ANNUAL MEMBERSHIP DUES MERCER COUNT	100.00	100.00
282 - MERCER COUNTY IMPROV AUTHORITY	PO 48288 RESO 23-222 (YEAR 3 OF 5)	113,826.84	113,826.84
289 - MGL FORMS-SYSTEMS, LLC	PO 48649 2026 Clerks Printing & Permits	728.00	
	PO 48812 OFFICE SUPPLIES	92.00	820.00
4697 - MID-ATLANTIC LAW ENFORCEMENT	PO 48930 MID ATLANTIC LAW ENFORCEMENT EXECUTIVE D	950.00	950.00
5348 - MJ PLANNING LLP	PO 48593 PLANNING SERVICES FOR MONUMENT HALL	4,950.00	4,950.00

List of Bills - Clearing Claims

Meeting Date: 04/13/2026 For bills from 03/24/2026 to 04/09/2026

Vendor	Description	Payment	Check Total
3606 - MOREEN, DENNIS	PO 48971 2026 SHOE REIMBURSEMENT	250.00	250.00
4260 - MULLER & BAILLIE, P.C.	PO 48910 BLANKET LEGAL	55.00	55.00
1489 - NAPA AUTO PARTS	PO 48160 BLANKET PARTS TV	203.99	203.99
4600 - NASSAU ELECTRIC LLC - PRINCETON	PO 48228 BLANKET/CONTRACTED SERVICES	452.00	452.00
322 - NATIONAL FIRE PROTECTION ASSOC	PO 48482 NFPA MEMBERSHIP RENEWAL FOR FRANK D'AMOR	225.00	225.00
162 - NATIONAL HIGHWAY PRODUCTS, INC.	PO 48351 BLANKET	1,156.00	1,156.00
338 - NC JEFFERSON PLUMBING HEATING & A/C	PO 49039 NC JEFFERSON PLUMBING HEATING & A/C - P	347.00	347.00
327 - NELSON GLASS & ALUMINUM CO.INC	PO 48933 RESOLUTION 26-090	3,088.30	3,088.30
832 - NEW JERSEY AMERICAN WATER	PO 49071 Water - SOC - Acct 1018-210051252446 - B	468.01	
	PO 49071 Water - SOC - Acct 1018-210051252446 - B	3,812.71	4,280.72
832 - NEW JERSEY AMERICAN WATER	PO 49072 Westminster Properties - Bundled Acct.#1	3,351.39	3,351.39
351 - NEW JERSEY CONFERENCE OF MAYORS	PO 49005 61st Annual Spring Conference 5/19-5/21	450.00	450.00
345 - NEW JERSEY OFFICE OF WEIGHTS &	PO 48911 INSPECTION AND TESTING OF TUNING FORKS	510.00	510.00
343 - NEW JERSEY STATE LEAGUE OF MUNICIPALITIE	PO 48513 Blanket 2026	560.00	560.00
343 - NEW JERSEY STATE LEAGUE OF MUNICIPALITIE	PO 48957 WEBINAR 4/10/26 The Ins and Outs of Fami	95.00	95.00
3170 - NJ ADVANCE MEDIA, LLC	PO 48648 2026 Advertising & Public Notices for th	100.00	100.00
1032 - NJ AMERICAN WATER	PO 49018 Water - Hydrants Acct 1018-210023719760	12,343.22	12,343.22
1032 - NJ AMERICAN WATER	PO 49022 Hydrants Water - Acct 1018-210023720128	38,017.22	38,017.22
803 - NJADVANCE MEDIA	PO 48935 AD # 0011060667- PUBLIC MEETINGS NOTICE	17.16	
	PO 48935 AD # 0011060667- PUBLIC MEETINGS NOTICE	44.04	61.20
7 - NORCIA CORPORATION	PO 48159 BLANKET SERVICE/PARTS TV	967.93	967.93
3650 - NV5	PO 47428 RESOLUTION 25-318 ROSEDALE RD FINAL DESI	58,687.93	58,687.93
252 - O'CONNELL, MARIA	PO 48945 VEHICLE REGISTRATIONS	359.97	359.97
1635 - PA MUNICIPAL, INC.	PO 48711 ROAD SIGNS QUOTE 1219543	2,029.62	2,029.62
591 - PACKET MEDIA LLC	PO 48647 2026 Advertising & Public Notices for th	154.50	154.50
591 - PACKET MEDIA LLC	PO 48647 2026 Advertising & Public Notices for th	897.11	897.11
591 - PACKET MEDIA LLC	PO 49032 2026 LEGAL NOTICE	117.46	117.46
4981 - PANDADOC, INC.	PO 48613 Blanket 2026	3,630.00	3,630.00
783 - PENN MEDICINE PRINCETON EAP	PO 48514 Blanket 2026	1,478.13	1,478.13
1055 - PENN MEDICINE PRINCETON HEALTH	PO 48436 BLANKET - SERVICES	2,382.00	2,382.00
1055 - PENN MEDICINE PRINCETON HEALTH	PO 48931 PRE EMPLOYMENT PHYSICALS DISPATCHERS SAB	400.00	400.00
1055 - PENN MEDICINE PRINCETON HEALTH	PO 49006 DRUG SCREEN - SEASONAL MAINTENANCE (RAMI	118.00	118.00
808 - POLAR INC.	PO 48366 BLANKET	42.45	
	PO 48367 BLANKET	177.45	219.90
5186 - PRIME LUBE INC.	PO 48162 BLANKET OILS/DEF FLUID TV	1,252.95	1,252.95
3910 - PRINCETON COMMUNITY HOUSING	PO 48946 RELEASE OF BALANCE OF INTEREST FOR INSPE	24.82	24.82
1348 - PRINCETON HYDRO, LLC	PO 42106 (Contract #1: Reso 23-313 + 24-85) (Cont	551.25	
	PO 47122 CONTRACT MT LUCAS RD STORMWATER CONSTRU	1,041.50	1,592.75
4880 - PRINCETON LIHTC URBAN RENEWAL LLC	PO 48947 RELEASE OF BALANCE OF INTEREST FOR INSPE	23.35	23.35
1626 - PRINCETON MERCER REGIONAL CHAMBER	PO 48983 March Membership Luncheon-Council Presid	65.00	
	PO 49069 2026 Dues (Organizational Membership)	325.00	390.00
592 - PRINCETON PUBLIC LIBRARY	PO 48954 Design Communications, LTD PO 25531	47,912.93	47,912.93
1277 - PRINCETON SUPPLY CORPORATION	PO 48371 BLANKET	2,226.38	2,226.38
5174 - PRO CAP 8 FBO FIRSTTRUST BANK	PO 48948 REDEMPTION FOR BL-9501 LT-1 CERT#25-0000	2,329.01	2,329.01
603 - PSE&G CO	PO 49013 GROVER PARK ACCT: 6637125105	5,435.86	5,435.86
603 - PSE&G CO	PO 49025 HILLTOP PARK ACCT: 1301303305	798.11	798.11
445 - PSE&G CO - SUMMARY ACCOUNT	PO 48956 Electric - Bundled Acct #13 000 010 03 -	41,555.49	41,555.49
445 - PSE&G CO - SUMMARY ACCOUNT	PO 48972 Electric and Gas - Bill Date March 18, 2	3,614.34	3,614.34
445 - PSE&G CO - SUMMARY ACCOUNT	PO 48974 WESTMINSTER - Electric and Gas - Acct. 4	33,251.09	33,251.09
445 - PSE&G CO - SUMMARY ACCOUNT	PO 49070 Electric - Bundled Acct 13 013 030 03 -	34,656.28	
	PO 49070 Electric - Bundled Acct 13 013 030 03 -	4,433.23	39,089.51
778 - RECREATION TRUST	PO 49008 REIMBRUSEMENT TO REC TRUST FOR PAPER SHR	482.29	482.29
1204 - RIGGINS INC.	PO 48375 BLANKET	9,196.35	9,196.35
623 - RND CONSULTING	PO 45265 RESO 25-21 & 25-372: INFORMATION TECHNOL	4,166.25	
	PO 48992 RESO 26-102 2026 INFORMATION TECHNOLOGY	7,425.00	11,591.25
3521 - RUTGERS CONTINUING STUDIES	PO 48984 RUTGERS TRAINING FOR JOHANNA PETERS - IN	483.00	
	PO 49049 RUTGERS TRAININGS FOR SINDY SANDOVAL - I	801.00	1,284.00
963 - RUTGERS UNIVERSITY OFFICE OF CONTINUING	PO 48973 PATHWAYS FOR ASPIRING LEADERS REGISTRATI	375.00	375.00
635 - RUTGERS/CAIT-LTAP	PO 48805 Work Zone Safety Awareness (Webinar) - J	125.00	
	PO 48805 Work Zone Safety Awareness (Webinar) - J	625.00	750.00
4617 - SANDRA GARRITY	PO 48999 2026 SHOE REIMBURSEMENT	250.00	250.00
4006 - SCARINCI & HOLLENBECK LLC	PO 48485 RESO 26-38 ENVIRONMENTAL LEGAL & LITIGAT	66,839.75	66,839.75

List of Bills - Clearing Claims

Meeting Date: 04/13/2026 For bills from 03/24/2026 to 04/09/2026

Vendor	Description	Payment	Check Total
1145 - SCOTT D WALTER	PO 49063 RETIREE Medical 12/14/25 to 12/27/25	4,772.22	4,772.22
5345 - SELENE ZANKHNA PAREKH	PO 48951 RELEASE OF BALANCE OF INTEREST FOR (PER	189.46	189.46
5099 - SHAH & RUBENSTEIN, LLC	PO 48070 RESO 26-7 2026 TAX APPEAL COUNSEL	18,742.34	18,742.34
2672 - SMITH + MANNING, LLC	PO 45573 ON-CALL GRAPHIC DESIGN SERVICES 1/1/25 -	4,500.00	4,500.00
1253 - SOFTWARE HOUSE INTERNATIONAL (SHI)	PO 48835 ZOOM MEETING - BUSINESS LICENSES - 1 YEA	13,317.02	
	PO 48878 ANNUAL FLEETIO SOFTWARE RENEWAL	36,638.00	49,955.02
835 - SOMERSET COUNTY EMERGENCY SERV	PO 48217 BLANKET - TRAINING	95.00	95.00
2458 - SPEEDY MART	PO 48468 PRISONER MEALS	13.92	13.92
3808 - SPIKES TROPHIES LIMITED	PO 48979 Nameplates for: Kerry Bruno, Deputy Mun	88.27	88.27
702 - STAPLES BUSINESS ADVANTAGE	PO 48210 OFFICE SUPPLIES	41.40	41.40
1219 - STONY BROOK REG.SEW.AUTH.	PO 49095 2nd Quarter 2025 Industrial User Surchar	22,995.00	22,995.00
761 - STROBEL, MICHAEL	PO 49053 ACCREDITATION BOOKS	306.88	306.88
1211 - SUSTAINABLE PRINCETON	PO 48061 RESO 26-33 - 2026 SERVICES RELATED TO SU	12,500.00	12,500.00
1206 - TAMASI, MARIANNE	PO 49028 Retiree - 2nd Qtr Medicare	2,313.18	2,313.18
3741 - TAYLOR SAPUDAR	PO 48977 2026 SHOE REIMBURSEMENT	250.00	250.00
5336 - THE OLIVER SPRINKLER CO., INC	PO 48602 BLANKET	1,690.00	1,690.00
4651 - THE VALLEY BUTCHER	PO 48066 RESO 25-406 & 26-89 2026 DEER PROCESSING	21,615.00	21,615.00
1184 - TORRES, CHRISTOPHER	PO 48970 2026 SHOE REIMBURSEMENT	250.00	250.00
960 - TRANS UNION RISK	PO 48518 MONTHLY CHARGES - ACCT #: 582727	336.40	336.40
766 - TRIPLE GLASS INC	PO 48167 BLANKET SERVICE TV	1,400.00	1,400.00
1167 - TRIUS INC.	PO 48169 BLANKET PARTS TV	2,121.70	2,121.70
2058 - ULINE	PO 48942 JUMBO DIGITAL CLOCK - DISPATCH	146.92	146.92
2592 - UNIFIRST CORPORATION	PO 48633 BLANKET - UNIFORMS FOR PUBLIC WORKS	2,239.48	
	PO 48634 BLANKET - UNIFORMS FOR PARKING	387.30	
	PO 48635 BLANKET - UNIFORMS FOR SOC	620.34	3,247.12
923 - UNITED PARCEL SERVICE	PO 49045 Acct. 6AF535 - Service Charge - 3/21/26	233.22	
	PO 49061 Acct. 6AF535 - Service Charge - 3/28/26	105.34	338.56
211 - UNITED SITE SERVICES	PO 48204 BLANKET/MISC. RENTAL	777.78	
	PO 48204 BLANKET/MISC. RENTAL	95.63	873.41
948 - VAN MATER, DAN	PO 48969 2026 SHOE REIMBURSEMENT	250.00	250.00
4220 - VANATTA, TIM	PO 48966 2026 SHOE REIMBURSEMENT	250.00	250.00
4069 - VASEFUL FLORAL AND GIFTS	PO 48873 WATLER HARRIS MEMORIAL	187.00	187.00
20 - VERIZON	PO 48503 MONTHLY TELEPHONE EXPENSE ACCT #: 957-13	562.39	562.39
20 - VERIZON	PO 48976 Phone - Acct. 250-717-293-0001-43 - Bill	487.92	487.92
20 - VERIZON	PO 49024 Phone - Acct. 756-981-704-0001-54 - Bill	96.42	96.42
20 - VERIZON	PO 49042 Phone - Acct. 357-046-267-0001-33 Bundle	3,273.61	3,273.61
4895 - VERIZON COMMUNICATIONS INC.	PO 48583 VEHICLE TRACKING SUBSCRIPTIONS: SOC & PW	2,264.73	2,264.73
1152 - VERMEER- NORTH ATLANTIC SALES & SER	PO 48170 BLANKET PARTS/SERVICE TV	282.69	
	PO 48401 BLANKET	282.69	565.38
1151 - VILLAGE OFFICE SUPPLY	PO 48580 PRINTING	410.04	410.04
973 - VISUAL COMPUTER SOLUTIONS (JOBS4BLUE)	PO 48615 Posiflex Kiosk for John Street	2,727.00	2,727.00
1146 - VOIP NETWORKS	PO 49065 Phone System - Acct #CORP-000105 - Bill	1,382.38	1,382.38
1024 - W.E. TIMMERMAN CO., INC.	PO 48172 BLANKET PARTS/SERVICE TV	550.12	550.12
4959 - WALTER R. EARLE BURLINGTON, INC	PO 48656 BLANKET-CONTRACT 24-FLEET-93147	1,281.59	1,281.59
2 - WB MASON CO	PO 48131 2026 BLANKET - BUILDING DEPT OFFICE SUPP	876.52	
	PO 48233 BLANKET / OFFICE SUPPLIES FOR RECREATION	287.77	
	PO 48406 BLANKET	80.16	
	PO 48408 BLANKET	249.04	
	PO 48439 BLANKET - SUPPLIES	1,269.00	
	PO 48446 BLANKET / OFFICE SUPPLIES 2026 HEALTH DE	213.45	
	PO 48456 BLANKET OFFICE SUPPLIES FOR POLICE DEPAR	471.71	
	PO 48499 BLANKET - HUMAN SERVICES GENERAL OFFICE	630.70	
	PO 48505 BLANKET FOR ENGINEERING - 2026	274.46	
	PO 48526 BLANKET - FINANCE/TAX/HR OFFICE SUPPLIES	33.33	
	PO 48552 BLANKET	341.79	4,727.93
4331 - WEDRIVEU, INC.	PO 48062 RESO 25-405 OPERATION & MAINTENANCE OF T	25,111.61	
	PO 48067 RESO 25-400 2026 PUBLIC TRANSIT SERVICES	30,180.33	55,291.94
3677 - WELLS FARGO VENDOR FIN SERV.	PO 48466 2026 Blanket - Wells Fargo	1,248.73	1,248.73
3773 - WINDY TOP AT PRINCETON, LLC	PO 49010 RELEASE OF INSPECTION FEES FOR WINDY TOP	1,037.53	1,037.53
1118 - YORK FENCE COMPANY	PO 48932 GROVER PARK FIELD 2 FENCE REPAIR	1,985.00	
	PO 48934 CP POOL FENCE REPAIR FROM STORM DAMAGE	1,650.00	3,635.00
1116 - YOUNG, LILIAN	PO 49027 2nd Quarter 2026 Medicare	2,320.63	2,320.63

List of Bills - Clearing Claims

Meeting Date: 04/13/2026 For bills from 03/24/2026 to 04/09/2026

Vendor	Description	Payment	Check Total
3351 - ZONE STRIPING	PO 46503 RESOLUTION 25-160 TRAFFIC STRIPING & PAV	68,281.01	68,281.01
TOTAL			1,528,399.74

Summary By Account

ACCOUNT	DESCRIPTION	CURRENT YR	APPROP. YEAR	NON-BUDGETARY	CREDIT
01-192-08-105-006	OTHER FEES & PERMITS - ZONING			240.00	
01-201-20-105-200	PERSONNEL - OE	6,042.97			
01-201-20-110-200	MAYOR & COUNCIL OE	727.99			
01-201-20-111-200	ADMINISTRATIVE & EXECUTIVE OE	49,840.62			
01-201-20-120-200	MUNICIPAL CLERK OE	1,879.61			
01-201-20-125-200	INFORMATION TECHNOLOGY - OE	11,245.90			
01-201-20-125-233	COMPUTER EXPENSE-SOFTWARE MAINT AND FEES	58,437.75			
01-201-20-130-200	FINANCE ADMINISTRATION OE	1,557.24			
01-201-20-145-200	COLLECTION OF TAXES OE	11.11			
01-201-20-151-200	DEFENSE OF TAX APPEALS OE	18,742.34			
01-201-20-155-200	LEGAL SERVICES & COSTS OE	83,716.38			
01-201-20-165-200	ENGINEERING SERVICES OE	274.46			
01-201-20-175-200	HISTORIC PRESERVATION COMMITTEE - OE	117.46			
01-201-21-180-200	REGIONAL PLANNING BD. - TWP - OE	701.00			
01-201-21-181-200	SUSTAINABLE PRINCETON	12,500.00			
01-201-21-185-200	ZONING COSTS - OE	253.04			
01-201-23-220-200	EMPLOYEE GROUP INSURANCE OE	14,152.37			
01-201-25-240-200	POLICE OE	13,263.28			
01-201-25-265-200	FIRE OE	13,580.85			
01-201-25-266-200	FIRE HYDRANT SERVICES OE	50,360.44			
01-201-25-267-200	FIRE FACILITIES OE	10,250.03			
01-201-25-268-200	FIRE INSPECTOR OE	1,514.86			
01-201-25-275-200	MUNICIPAL PROSECUTOR OTHER EXPENSES	14,400.00			
01-201-26-290-200	ROAD REPAIRS & MAINTENANCE OE	15,674.82			
01-201-26-305-200	GARBAGE & TRASH REMOVAL OE	113,826.84			
01-201-26-310-200	PUBLIC BUILDINGS & GROUNDS OE	11,960.72			
01-201-26-315-200	VEHICLE MAINT. - ADMIN. OE	14,921.25			
01-201-27-330-200	BOARD OF HEALTH OE	3,238.45			
01-201-27-340-200	ANIMAL CONTROL OE	627.79			
01-201-27-343-200	DEER MANAGEMENT PROGRAM - OE	21,615.00			
01-201-27-345-200	HUMAN SERVICES OE	5,538.30			
01-201-28-370-200	JOINT RECREATION BOARD OE	5,249.35			
01-201-28-375-200	PARK MAINTENANCE OE	3,939.46			
01-201-31-430-200	ELECTRICITY & GAS OE	25,033.95			
01-201-31-431-200	NATURAL GAS OE	12,198.04			
01-201-31-435-200	STREET LIGHTING OE	31,527.10			
01-201-31-440-200	TELEPHONE OE	4,982.76			
01-201-31-445-200	WATER OE	1,990.54			
01-201-31-455-200	SEWER FACILITIES OPERATING OE	7,951.39			
01-201-31-460-200	GASOLINE OE	26,767.91			
01-203-20-125-200	(2025) INFORMATION TECHNOLOGY - OE		4,166.25		
01-203-20-155-200	(2025) LEGAL SERVICES & COSTS OE		561.00		
01-203-20-165-200	(2025) ENGINEERING SERVICES OE		4,500.00		
01-203-21-180-200	(2025) REGIONAL PLANNING BD. - TWP - OE		2,670.00		
01-203-23-220-200	(2025) EMPLOYEE GROUP INSURANCE OE		5,899.60		
01-203-25-240-200	(2025) POLICE OE		200.00		
01-203-28-375-200	(2025) PARK MAINTENANCE OE		2,728.87		
01-203-31-456-200	(2025) STONY BROOK REGIONAL SA OE		4,358.21		
01-203-31-457-200	(2025) STONY BROOK INDUSTRIAL USER OE		18,636.79		
01-214-55-900-062	THIRD PARTY LIENS PAYABLE-REDEMPTIONS			1,129.01	
01-260-05-100	DUE TO CLEARING/CLAIMS			0.00	716,903.10
01-286-55-000-005	RES - FOR TAX SALE PREMIUM			1,200.00	

ACCOUNT	DESCRIPTION	CURRENT YR	APPROP. YEAR	NON-BUDGETARY	CREDIT
TOTALS FOR	CURRENT FUND	670,613.37	43,720.72	2,569.01	716,903.10
02-213-44-909-301	BODY ARMOR			760.86	
02-213-44-999-301	TJX LAW ENFORCEMENT GRANT			5,000.00	
02-260-05-100	DUE TO CLEARING/CLAIMS			0.00	5,760.86
TOTALS FOR	GRANT FUND	0.00	0.00	5,760.86	5,760.86
04-215-20-023-000-000	Ordinance 2020-23 Various Capital Imprv			58,687.93	
04-215-21-021-000-000	Ordinance 2021-21 Various Capital Improvements			126,917.90	
04-215-22-018-000-000	Ordinance 2022-18 NJ I-Bank			80,928.25	
04-215-22-019-000-000	Ordinance 2022-19 Various Capital Improvements			1,650.00	
04-215-23-017-000-000	Ordinance 2023-17 Sewer Improvements			736.50	
04-215-23-019-000-000	Ordinance 2023-19 I-Bank Improvements			9,412.96	
04-215-23-021-000-000	Ordinance 2023-21 Various Capital Improvements			12,497.92	
04-215-24-014-000-000	Ordinance 2024-14 Various Capital Improvements			84,416.60	
04-215-24-017-000-000	Ordinance 2024-17 Sewer Improvements (I-Bank)			28,031.68	
04-215-25-007-000-000	Ordinance 2025-07 Various Capital Improvements			265,315.83	
04-260-05-100	DUE TO CLEARING/CLAIMS			0.00	668,595.57
TOTALS FOR	GENERAL CAPITAL FUND	0.00	0.00	668,595.57	668,595.57
05-201-02-007-200	PARKING OE	36,801.77			
05-201-02-009-000	JITNEY EXPENSES	30,180.33			
05-260-05-100	DUE TO CLEARING/CLAIMS			0.00	66,982.10
TOTALS FOR	PARKING UTILITY OPERATING FUND	66,982.10	0.00	0.00	66,982.10
12-201-20-125-200	OPEN SPACE - OTHER EXPENSE - PARK MAINT	25,532.98			
12-260-05-100	DUE TO CLEARING/CLAIMS			0.00	25,532.98
TOTALS FOR	OPEN SPACE FUND	25,532.98	0.00	0.00	25,532.98
17-260-05-100	Due To Claims/Clearing			0.00	11,123.21
17-290-20-000-000	PROFESSIONAL FEES			6,759.75	
17-290-40-000-000	PERFORMANCE GUARANTEE			2,693.86	
17-290-50-000-000	INSPECTION FEES			1,669.60	
TOTALS FOR	ESCROW	0.00	0.00	11,123.21	11,123.21
21-201-12-110-200	CONSTRUCTION EXPENSES - OE	2,772.52			
21-260-05-100	DUE TO CLAIMS/CLEARING			0.00	29,234.13
21-285-56-072-333	P.O.A.A. COURT TRUST			1,350.00	
21-285-56-087-333	P.U. - COMMUNITY MASS TRANSIT			25,111.61	
TOTALS FOR	TRUST FUND	2,772.52	0.00	26,461.61	29,234.13
40-201-20-105-200	AFFORDABLE HOUSING BOARD OE	4,267.79			
40-260-05-100	DUE TO CLAIMS/CLEARING			0.00	4,267.79
TOTALS FOR	AFFORDABLE HOUSING UTILITY	4,267.79	0.00	0.00	4,267.79

Total to be paid from Fund 01 CURRENT FUND	716,903.10
Total to be paid from Fund 02 GRANT FUND	5,760.86
Total to be paid from Fund 04 GENERAL CAPITAL FUND	668,595.57
Total to be paid from Fund 05 PARKING UTILITY OPERATING FUND	66,982.10
Total to be paid from Fund 12 OPEN SPACE FUND	25,532.98
Total to be paid from Fund 17 ESCROW	11,123.21
Total to be paid from Fund 21 TRUST FUND	29,234.13
Total to be paid from Fund 40 AFFORDABLE HOUSING UTILITY	4,267.79

ACCOUNT	DESCRIPTION	CURRENT YR	APPROP. YEAR	NON-BUDGETARY	CREDIT
---------	-------------	------------	--------------	---------------	--------

1,528,399.74



Municipality of Princeton, NJ

400 Witherspoon St
Princeton, NJ 08540

Staff Report

File #: R-26-127

Agenda Date: 4/13/2026

Agenda #: 2.

Resolution of the Mayor and Council of Princeton Authorizing a Shared Services Agreement for Specialized Health Services with the Township of Hamilton in the Not to Exceed Amount of \$4,000.00

WHEREAS, Princeton is in need of provision of certain local public health services (services related to Sexually Transmitted Diseases - STD's); and

WHEREAS, Princeton is desirous of entering into a Shared Services Agreement to provide certain public health services related to STD's with Hamilton Township; and

WHEREAS, a Shared Services Agreement has been drafted pursuant to N.J.S.A. 40A:65-1, et seq. effectuating the intent of the parties and is annexed hereto;

WHEREAS, the Certified Financial Officer has certified that the Municipality of Princeton has appropriated sufficient funds for these services in account 01-201-27-330-281; and in the

not to exceed amount of \$4,000.00; and

NOW, THEREFORE, BE IT RESOLVED, the Mayor and Clerk are hereby authorized to execute the Shared Services Agreement with Hamilton Township for the provision of certain public health services related to STD's.



MUNICIPALITY OF PRINCETON

Department of Health &
Community Services
Health Department

1 Monument Hall
Princeton, NJ 08540
(609) 497- 7608

healthdepartment@princetonnj.gov

MEMORANDUM

To: Bernard Hvozdovic, *Administrator*
Dawn Mount, *Clerk*
From: Jeffrey C. Grosser, MHS, HO, *Deputy Administrator/Health Officer*
Subject: Shared Services Agreement with Hamilton Township for Health Services
Date: April 13, 2026

Bernie,

I have attached the shared services agreement with the Township of Hamilton for Sexually Transmitted Disease (STD) clinic services. This service is aligned with the national and state efforts to assure access to high quality health services according to Healthy People 2030 and New Jersey Public Health Standards, N.J.A.C. 8:52. This contract is for a not to exceed amount of \$4,000.00.

Best Regards,

Jeffrey C. Grosser
Deputy Administrator/Health Officer

SHARED SERVICES AGREEMENT FOR HEALTH SERVICES
TOWNSHIP OF HAMILTON & THE TOWNSHIP OF PRINCETON

January 1, 2026 to December 31, 2026

This Agreement made this **16th** day of **December, 2025**, by and between the **Township of Hamilton**, County of Mercer, a municipal corporation of the State of New Jersey, with principal offices located at 2090 Greenwood Avenue, Hamilton, New Jersey 08650; and the **Township of Princeton**, County of Mercer, a municipal corporation of the State of New Jersey, with principle offices located at 400 Witherspoon Street, Princeton, New Jersey 08540.

Witnesseth:

Whereas, the Township of Princeton is responsible by law for the protection of public health and wishes to provide certain health services for its residents; and

Whereas, the Township of Princeton desires to contract with the Township of Hamilton for the provision of those health services; and

Whereas, the Township of Hamilton is agreeable to providing health services to the Township of Princeton for a fee and upon certain specified conditions; and

Whereas, the *Uniform Shared Services and Consolidation Act, N.J.S.A. 40A:65-1, et seq.*, permits local units of this State to enter into a contract with any other local unit for the joint provision within their combined jurisdictions of any service which any party to the Agreement is empowered to render within its own jurisdiction; and

Whereas, the Township of Hamilton and the Township of Princeton have authorized and approved this Agreement by their respective Resolutions, duly adopted pursuant to *N.J.S.A. 40A:65-1, et seq.* of the *Uniform Shared Services and Consolidation Act*, annexed hereto as **Exhibit A**;

Now, Therefore, in consideration of the mutual agreements and covenants herein contained, the parties agree as follows:

1. **Scope of Services**: The Township of Hamilton agrees to provide to the Township of Princeton, for the benefit of the residents of the Township of Princeton, certain health services on an as needed basis.

2. **Fees:** The fees payable by the Township of Princeton to the Township of Hamilton for the performance of health services shall be as set forth in *Code of the Township of Hamilton, New Jersey, Chapter 215, Fees, § 215-6. Department of Health, Recreation, Senior and Veterans Services § 215-6A(10)* annexed hereto as **Exhibit B**.

3. **Billing and Payment:** The Township of Hamilton will issue quarterly bills for services rendered to the Township of Princeton. The bills will be issued by the fifteenth (15th) day of the succeeding quarter and will be payable within thirty (30) days of issuance. The first quarter will run from January 1st – March 31st; the second quarter will run from April 1st – June 30th; the third quarter will run from July 1st – September 30th; and the fourth quarter will run from October 1st – December 31st.

4. **Liability:** The Township of Hamilton and the Township of Princeton shall be responsible for acts of their own negligence consistent with the provisions of the *New Jersey Tort Claims Act, N.J.S.A. 59:1-1 et seq.*, arising out of or related to performance of any activity under the terms of this Agreement.

5. **Effective Date/Termination:** This Agreement shall be for twelve (12) months effective January 1, 2026 and ending December 31, 2026.

6. Each party shall notify the other in writing sixty (60) days before expiration of this Agreement if it desires to continue services and negotiate a new contract for the 2027 Calendar Year.

IN WITNESS WHEREOF, the parties hereto have set their hands and seals on the respective date indicated below:

TOWNSHIP OF HAMILTON

TOWNSHIP OF PRINCETON

JEFFREY S. MARTIN, MAYOR

MARK FREDI, MAYOR

ATTEST:

ATTEST:

ALISON SABO, RMC
MUNICIPAL CLERK

DAWN MOUNT
MUNICIPAL CLERK

DATED:

DATED:

EXHIBIT A

TOWNSHIP OF HAMILTON COUNTY OF MERCER, NEW JERSEY

RESOLUTION

No. **25-505**

APPROVED AS TO FORM AND LEGALITY

TOWNSHIP ATTORNEY

FACTUAL CONTENTS CERTIFIED TO BY

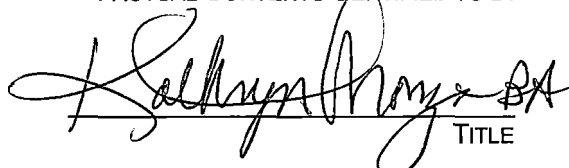
TITLE

RESOLUTION AUTHORIZING AND APPROVING A 2026 SHARED SERVICES CONTRACT FOR HEALTH SERVICES BETWEEN THE TOWNSHIP OF HAMILTON AND THE TOWNSHIP OF PRINCETON

Whereas the Township of Princeton desires to contract with the Township of Hamilton for the provision of certain professional health clinic services for the period January 1, 2026 to December 31, 2026; and

Whereas the Township of Hamilton has agreed to provide certain health services to the Township of Princeton pursuant to the fees outlined in the *Code of the Township of Hamilton, New Jersey, Chapter 215, Fees, § 215-6, Department of Health, Recreation, Senior and Veterans Services, § 215-6A(10)*; and

Whereas such agreements are authorized pursuant to N.J.S.A. 40A:65-1 et seq.; and

Whereas this contract is in the best interest of the Township of Hamilton;

Now, Therefore, Be It Resolved by the Council of the Township of Hamilton, in the County of Mercer and State of New Jersey, that the shared services contract between the Township of Hamilton and the Township of Princeton for the provision of certain professional health clinic services is authorized and accepted, and that the proper officials of the Township of Hamilton are authorized to execute said contract.

Be It Further Resolved that the contract shall take effect upon the adoption of the appropriate resolution by the Township of Princeton and the execution of the contract by the parties in accordance with N.J.S.A. 40A:65-1 et seq.

Be It Further Resolved that a copy of this resolution and agreement shall be forwarded to the Director of the Division of Local Government Services as per N.J.S.A. 40A:65-4(3)b.

ADOPTED BY COUNCIL ON DECEMBER 16, 2025



PRESIDENT

MUNICIPAL CLERK

RECORD OF VOTE						
COUNCIL	AYE	NAY	N.V.	A.B.	RES.	SEC.
ANTHONY P. CARABELLI, JR.	✓				✓	
NANCY PHILLIPS	✓					
CHARLES F. WHALEN	✓			✓		
PASQUALE "PAT" PAPERIO, JR.	✓					✓
RICHARD L. TIGHE, JR	✓					

X – Indicates Vote A.B. – Absent N.V. – Not Voting RES. - Moved SEC. – Seconded

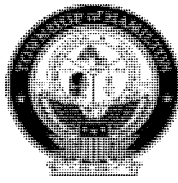
Jeffrey S. Martin
Mayor



Public Health
Prevent. Promote. Protect.

EXHIBIT B

Item #CA11.

Kathleen Fitzgerald, Director
Chris Hellwig, Health Officer

TOWNSHIP OF HAMILTON DEPARTMENT OF HEALTH, RECREATION, SENIORS, AND VETERANS SERVICES

DIVISION OF HEALTH – 2100 Greenwood Avenue, Hamilton, NJ 08609 *Office (609) 890-3828 *Fax (609) 890-6093

2026 Fee Schedule for Certain Clinical Services

Fees found in Section 215-6 (10) of the Hamilton Township Code

For current Division of Health clinic schedules, please visit www.hamiltonnj.com/health.

Exposure control plan

Name / description	Current Fee
BBP Plan	\$300
TB Plan	\$300
Both Plans	\$500

Blood borne pathogen/TB training

Name / description	Current Fee
Initial training session	\$500 for up to 30 employees; \$10 per each additional employee over 30
Initial TB training only	\$250 for up to 30 employees; \$10 per each additional employee over 30
Yearly retraining	\$300 for up to 30 employees; \$10 per each additional employee over 30

Hepatitis B vaccine

Name / description	Current Fee
Hepatitis B vaccine	\$70 per vaccination
Twinrix (Hepatitis A and Hepatitis B)	\$100 per vaccination

Mantoux tuberculin testing (PPD)

Name / description	Current Fee
PPD administration	\$30 per employee

Sexually transmitted disease (STD) clinic services

Name / description	Current Fee
Contracted STD clinic visit	\$100 per patient as per contract

Pneumonia/flu

Name / description	Current Fee
Non-Township residents, private sector and businesses	\$200

Blood lead investigations

Name / description	Current Fee
Investigation and follow-up	\$60 per hour

Child health conferences

Name / description	Current Fee
Assessment, counseling, examination and immunizations	\$100 per patient as per contract

Health education services

Name / description	Current Fee
Assessment, planning and implementation	\$200 per hour



Municipality of Princeton, NJ

400 Witherspoon St
Princeton, NJ 08540

Staff Report

File #: R-26-128

Agenda Date: 4/13/2026

Agenda #: 3.

Resolution of the Mayor and Council of Princeton Authorizing Appointments to Boards, Commissions, and Committees

BE IT RESOLVED by the Mayor and Council of Princeton:

The following appointments are hereby made:

<u>Name and Board</u>	<u>Term</u>	<u>Expires</u>
Board of Parks & Recreation Commissioners		
Danielle Boyle, Alternate 1	5 year	1/1/2031



Municipality of Princeton, NJ

400 Witherspoon St
Princeton, NJ 08540

Staff Report

File #: R-26-129

Agenda Date: 4/13/2026

Agenda #: 4.

Resolution of the Mayor and Council of Princeton Approving the Placement of Pole Banners along Nassau Street by the Princeton Symphony Orchestra, Saturday, May 30 and taken down on Saturday, June 13, 2026

WHEREAS, the Princeton Symphony Orchestra will be announcing their Princeton Festival; and

WHEREAS, Princeton Symphony Orchestra has requested permission to install pole banners along Nassau Street with approval of the Office of Community and Regional Affairs at Princeton University beginning Saturday, May 30 and taken down on Saturday, June 13, 2026 to advertise this event to the entire Princeton Community; and

WHEREAS, this banner will be promptly removed after its use as required by Princeton ordinances; and

WHEREAS, in accordance with Princeton Ordinance 14-32 any banner that is removed by Princeton will be held by Princeton for thirty (30) days and then disposed of; and

WHEREAS, in accordance with Princeton Ordinance 14-32 any applicant failing to remove a banner will not be permitted to display any banner for the succeeding two years; and

NOW THEREFORE BE IT RESOLVED that the Mayor and Council hereby approve placement of said banner on Washington Road in accordance with Princeton Ordinances 14-28 to 14-32.